

m
Materasso

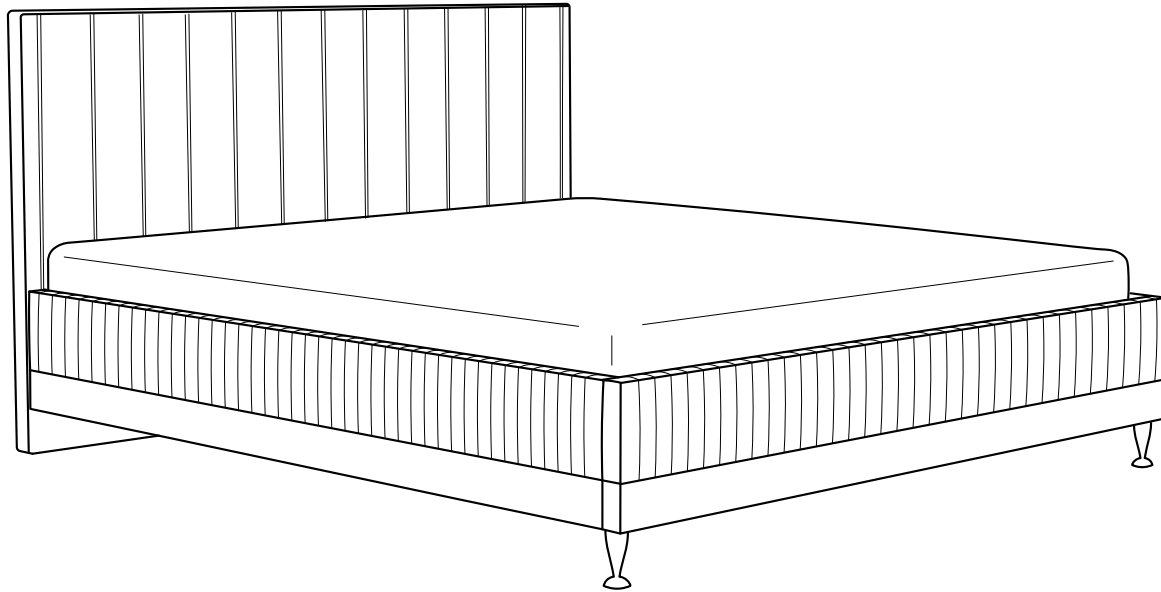

CZ

m
Materasso
Pro chvíle, na kterých záleží...



- 15 DAMIANI SET
- 17 CRISTAL SET
- 19 SPECTRA SET
- 21 CORONA SET
- 23 FRANCESCA LUX SET
- 25 SOUL SET

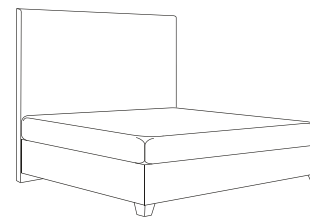

- 26 MONZANO
- 28 LINORA
- 31 ENZO
- 33 SANDRO
- 35 CHESS
- 37 ZINA
- 39 DUNA
- 41 CRISTAL
- 43 LA SPEZIA
- 45 DAMIANI
- 47 SOUL
- 49 CORIUM
- 51 FOREST
- 53 CHESTERFIELD
- 55 RHOMBUS
- 57 WILD
- 59 KINGSTONE
- 61 HONEY

- 62 MELVA
- 64 SPECTRA
- 66 HORIZONTAL
- 68 NAVY
- 70 ENIF
- 72 GEMINI
- 75 FRANCESCA LUX
- 77 CLAUDIA LUX
- 78 ALESIA
- 81 VEGA
- 83 BELLATRIX
- 84 ATLAS
- 86 CORONA
- 88 MIRACH
- 90 PARIS
- 92 VIENNA
- 94 NOBILIA
- 97 ARGENTINA
- 99 SIRIUS
- 101 VELORUM
- 103 CORIUM SLIDE
- 105 WALL
- 107 TWINS

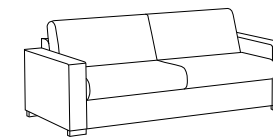

- 109 AMIRA
- 111 SIESTA
- 113 SOFABED BARI
- 115 SOFABED TORVI
- 117 SOFABED SINGLE
- 119 SOFABED DOUBLE

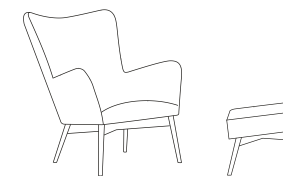

- 120 BOUDOIR MONT BLANC
- 121 MONT BLANC
- 122 BOSS
- 123 MOON
- 124 PUFF
- 126 BOUDOIR BREEZE
- 127 BREEZE
- 128 DE LUXE
- 129 MODERN
- 130 CUT
- 130 CASTELO
- 130 CROSS

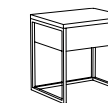

- 131 DAMIANI SWISS
- 131 VITO
- 131 PIETRO
- 132 NIMO
- 132 VITORIO U
- 132 VITORIO L
- 133 ANA
- 133 ANITA
- 134 INDUSTRY
- 134 HEAVY OAK
- 134 OAK
- 135 DAMIANI
- 135 CUBE
- 135 LA SPEZIA

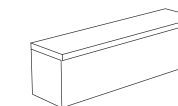

- 136 TABURET BENCH

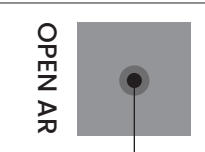

Chcete si představit, jak bude postel vypadat přímo u vás v pokoji?

VYUŽIJTE FUNKCI OPEN AR U VYBRANÝCH MODELŮ!

Stačí naskenovat QR kód mobilem nebo tabletem a postel si můžete prohlédnout přímo u vás doma – sladte ji se stylem svého bydlení, prohlédněte si ji ze všech úhlů a ujistěte se, že se perfektně hodí.



Společnost Materasso s. r. o. je rodinná firma, která je na trhu již více než 30 let.

Na českém i evropském trhu a v posledních letech i na trzích mimoevropských je známá výrobou certifikovaných zdravotních matrací, designových postelí, interiérových doplňků (taburety, křesla, noční stolky...) a postelových doplňků (přikrývky, polštáře, matracové chrániče).

Díky neustále se rozrůstajícímu sortimentu našich výrobků, použití kvalitních materiálů, dodržování certifikovaných výrobních postupů a následnému servisu rozšiřujeme řady spokojených zákazníků - a to běžných klientů i profesionálů (interiérových designérů nebo hoteliérů).

Ložnice je nejdůležitějším a nejméně známým místem ve Vaší domácnosti.

Je to místo odpočinku a relaxace těla i všech smyslů po celodenní námaze. Tam získáváte sílu a připravujete se na nové výzvy.

Uvědomujeme si, že ústředním bodem ložnice je postel, která jí dává duši i charakter. Proto kolekci našich postelí charakterizuje nejen pevná konstrukce a perfektní vypracování, ale zároveň i krásný design, bohatý výběr potahových látek a jejich barevného provedení.

Ve spojení s nabídkou našich zdravotních matrací Vám poskytneme komfort a pohodlí té nejvyšší úrovně. Velký důraz klademe na funkčnost a možnost vytvoření modelů postelí přesně podle Vašich představ.

Díky velkému množství variací v nabídce tvarů a designů, také barev a doplňkových funkcí, určitě najdete v naší nabídce postel, kterou dotvoříte styl Vašeho interiéru tak, aby se ložnice stala nejužitečnějším místem ve Vašem domě.

Stavíme na silném týmu kvalifikovaných odborníků s dlouholetými zkušenostmi v oblasti výroby ortopedických matrací a postelí a zároveň na kvalitě našich výrobků.

Nabízíme možnost kombinace různých spacích systémů s bohatým výběrem moderních čel postelí, v různých designech a způsobech spracování. Vyrábíme různé typy korpusů postelí s užšími nebo silnějšími bočnicemi, postele ve standardní i atypické délce, v pohodlných boxspringových verzích známých především z hotelů.

Zákazník si může zvolit verzi bez nebo s úložným prostorem. Individuální je i výběr roštů od klasických pevných, s výklopem nebo s elektrickým pohonem polohování.

Neustále sledujeme nové technologie a trendy v interiérovém designu. Jejich následná aplikace do výroby nám umožnila vytvořit ucelenou a designově zdařilou kolekci postelí i celých ložnicových setů. Design a styl postelí je umocněn použitím kvalitních čalounických potahových látek. V naší nabídce najdete nejen látky s originálními vzory a strukturami, ale také látky se speciální úpravou pro snadné čištění, látky odolávající absorpci tekutin a nečistot. Každou postel z nabídky (v jakémkoliv provedení korpusu), je možné doladit vhodným výběrem nožiček v rozmanitých provedeních ať už jde o materiál, tvar nebo výšku.



Možnosti uložení matrace:

1. SYSTÉM SE ZAPUŠTĚNÍM MATRACE:

Matrace je zapuštěná do rámu postele, což znamená, že vnější rozměr postele je větší než rozměr matrace.

Tento způsob je možný pouze u rámových postelí.



2. SYSTÉM CORIUM:

Matrace je položena na spací systém (rámová postel nebo boxspring), přičemž vnější rozměry matrace jsou totožné s rozměry spacího systému postele.

POSTELOVÉ SYSTÉMY

Každý postelový systém je možné kombinovat s libovolným čelem postele a nožičkami. Můžete si vybrat z velké nabídky kvalitních čalounických látek.

Ke každé posteli je možné objednat i taburet, křeslo nebo podnožku ke křeslu ve stejné látce.

Výšky spacích systémů jsou uvedeny bez nožiček. Všechny postele v rámci dětského a teenager programu vyrábíme už od šířky 90 cm.

Celý korpus postele (bez čela a roštů) je balený v kartónové krabici, což zjednodušuje přepravu a zlepšuje ochranu při manipulaci.

Ve všech montovaných spojích u rámových korpusů jsou použity matice a šrouby s metrickým závitem, umožňující i opětovnou bezproblémovou montáž.

POUŽITÉ ZKRATKY

UP – úložný prostor

BV – boční výklop

NV – nožní výklop

NEW



BOXSPRING SLIDE

Boxspring je navržen s ohledem na maximální komfort a funkčnost. Díky kombinaci taštičkové pružiny a vrstvy PUR 35 ve vrchní části boxspringu poskytuje optimální pohodlí pro spaní. Tato kombinace zajišťuje dostatečnou oporu těla a současně pružnost, která přispívá k relaxačnímu a zdravému spánku.

Tento boxspring je ideální volbou pro ty, kteří ocení praktičnost zakomponované extra přistýlky bez kompromisů v pohodlí. Lineární výsuvná kování umožňují snadnou a plynulou manipulaci. Matraci přistýlky si můžete vybrat dle vlastních preferencí, přičemž maximální výška matrace je 20 cm.

NEW



HIGHLIGHT

Box je čalouněný ve stejné látce jako čelo postele a na ložné ploše boxspringu je speciální potahová látka s úpravou ANTISLIP, která dokonale fixuje matraci proti posunu.

Výška bočnice boxu je 10 cm.



BOXSPRING 22-32 CM

Je nejpokrokovější postelový systémem. Jeho oblíbenost je dána specifickou konstrukcí: masivní rám boxspringu obklopuje pružinovou kostru, která zajišťuje bodově přizpůsobivý podklad pod matrací, zlepšuje kopírovací vlastnosti a celkovou přizpůsobivost použité matrace. Takové složení vytváří výjimečný systém dvojího kopírování přirozeného tvaru těla.

Boxspring je čalouněný ve stejné látce jako čelo postele a na ložné ploše boxspringu je speciální potahová látka s úpravou ANTISLIP dokonale fixující matraci proti posunu. Výška bočnice boxspringu je 22 nebo 32 cm. Matrace není zapuštěná do rámu postele, ale lícuje s boxspringem.



BOX UP VÝKLOP MAXI

UP MAXI 40, UP MAXI 100 a taky UP MAXI electric je ideálním řešením pro všechny, kteří hledají komfortní postel, která je doplněna o velký úložný prostor uvnitř postele. Konstrukce zmenšuje požadavky na prostor v ložnici a dovoluje použití i rozměrově větší matraci oproti tradičnímu typu postele.

Úložný prostor bez vnitřních dělicích příček poskytuje výjimečně velký prostor s výborným přístupem po celé ploše. Box UP MAXI 40 bude bez problémů zvedat matraci do celkové hmotnosti 40 kg. Pro matrace s vyšší hmotností je určen systém UP MAXI 100. Ten disponuje 4 ks kování a pístů pro snadné zvedání víka úložného prostoru spolu s těžkými matracemi. Zvedání víka u UP MAXI ELECTRIC zajišťuje elektrický mechanismus. Výška boxu je 32 cm.



UP WOOD

Je určen pro ty, kteří potřebují více úložného prostoru v ložnici a také upřednostňují jednu společnou partnerskou matraci. Rám postele má tloušťku 5 nebo 8 cm, a výšku 30 nebo 35 cm.

Vybaven je konstrukcí a roštem z masivního bukového dřeva. Rošt se z přední části postele vyklápí pomocí kování s pneumatickými písty, které usnadňují přístup do úložného prostoru i při použití těžkých matrací.



UP METAL

Je určena pro ty, kteří potřebují více úložného prostoru v ložnici a také upřednostňují jednu společnou partnerskou matraci.

Rám postele má 5 nebo 8 cm tloušťku, 30 nebo 35 cm výšku.

Vybaven je speciálním roštem s kovovou konstrukcí, který se z přední části postele vyklápí pomocí kování s pneumatickými písty, které usnadňují přístup do úložného prostoru i při použití těžkých matrací. Kovový rám roštu je osazen předpjatými lamelami. Demontáží dna v úložném prostoru získáme přístup pod celou plochou postele, což oceníte především při úklidu.



UP METAL LIFT-UP

Vylepšením UP metal je METAL LIFT-UP, usnadňující přístup do úložného prostoru v oblasti čela postele a také velmi zjednodušuje výměnu ložního prádla.

METAL LIFT UP musí být na posteli s těžšími matracemi, jinak se s ním špatně manipuluje.



UP BV | UP NV

Designová postel UP BV a UP NV (s polohováním hlavy), s použitím dřevěných výklopných roštů. Pro tuto postel je vhodné použít dvě samostatné matrace, aby bylo možné plnohodnotně využívat výklopné rošty.

Matrace při použití roštů METAL, DOBLE NV a DOBLE BV je zapuštěna 6 cm od vrchní hrany bočnice.

V provedení Corium lze rošt METAL namontovat ve výšce boční hrany bočnice a matrace je uložena i na roštu, i na bočnicích. Taková postel bude působit dojmem boxspringu a šířka postele (včetně bočnic) bude stejná s šířkou matrace.



BEZ ULOŽNÉHO PROSTORU

Designová postel je určena pro ty, kteří nepotřebují úložný prostor v posteli. Rám postele je podobný jako postelí s UP, neobsahuje však upevnění pro dno úložného prostoru.

V tomto rámu je možné použít všechny typy roštů pod matraci: od jednoduchých masivních laťových roštů, přes laťové masivní v rámu, pružné lamelové, polohovatelné, až po modely s plynulým elektrickým polohováním. pro absolutní pohodlí během spánku, ale i pro chvíle aktivního odpočinku, např. při čtení. Korpusy vyrábíme ve dvou různých tloušťkách panelů: 5 nebo 8 cm a třech výškách: 15, 30 nebo 35 cm.



BOXSPRING MOBIL

Konstrukce postele je shodná s boxspringem 22/32 a je doplněna o funkci plynulého polohování hlavy, zádové části a nohou pomocí elektromotoru s ovládačem. Tento typ postelí nemá vystupující bočnice a polohování umožňuje nastavení nejlepší pozice pro odpočinek. Jiná je poloha pro spaní, jiná pro aktivní odpočinek (např. čtení), jiná při regeneraci bolavých nohou.

Boxspring Mobil ideálně spolupracuje s matracemi ze studených pěn, s anatomicky prořezanými jádry, latexovými matracemi a také matracemi z „líných“ termoelastických pěn.

Tyto matrace přesně kopírují tvar roštu při polohování. Výška boxspringu je 32 cm.

SETY POSTELÍ, ČALOUNĚNÍ STĚN A DOPLNKŮ

Novinka, která je velmi vítaná nejen ze strany interiérových designérů a hoteliérů, ale stále více i běžných spotřebitelů, je možnost si z naší nabídky ke každé posteli objednat i taburet, noční stoly, křeslo nebo podnožku ke křeslu ve stejné čalounické látce jako je látka postele.

Pro ty, kteří již mají vlastní kvalitní postel (např. z masivu) a plánují povznést interiér své ložnice, nabízíme možnost kombinovat ve stejné čalounické látce jednotlivé interiérové doplňky navzájem nebo spolu s některým z variant pro čalounění stěny za čelem postele. SET (kombinace) postele a některého nebo všech ze zmíněných interiérových doplňků v identické čalounické látce umocňuje celkový dojem z Vaší ložnice, navozuje žádaný konečný pocit elegance a luxusu a je odrazem Vašeho jedinečného vkusu a preferencí.





DAMIANI SET

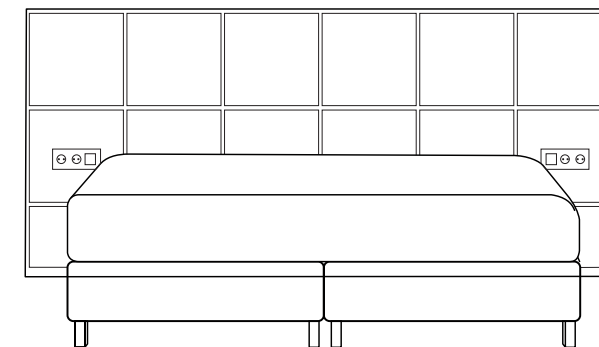

DAMIANI
(p. 45)

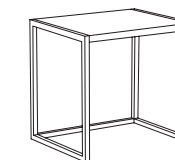
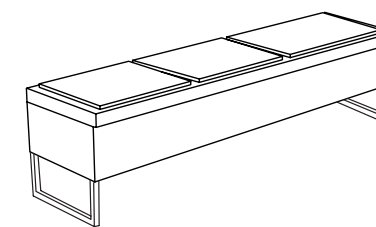

DAMIANI
(p. 135)



CRISTAL SET

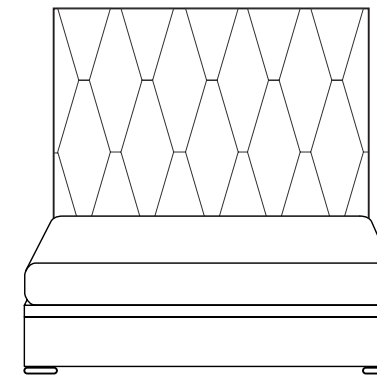

CRISTAL
(p. 41)

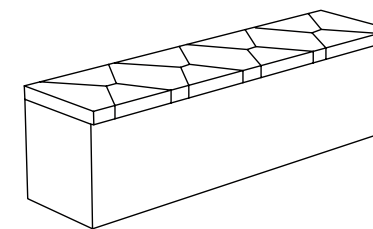

TABURET
No. 5 (p. 137)

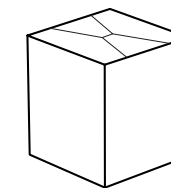

CUBE - CRISTAL
(p. 135)



SPECTRA SET

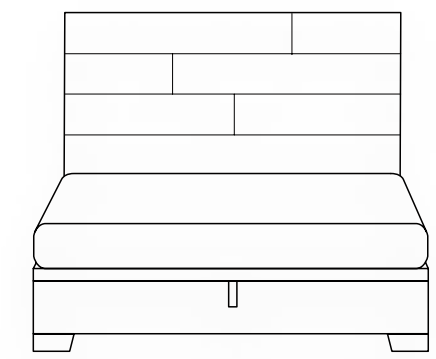

SPECTRA
(p. 64)

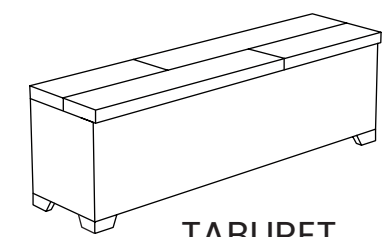

TABURET
No. 7 (p. 137)

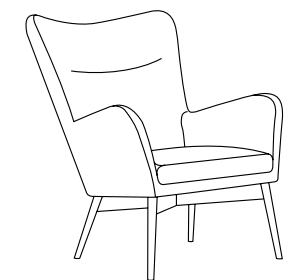

BREEZE
(p. 127)



CUT
(p. 130)



CORONA SET

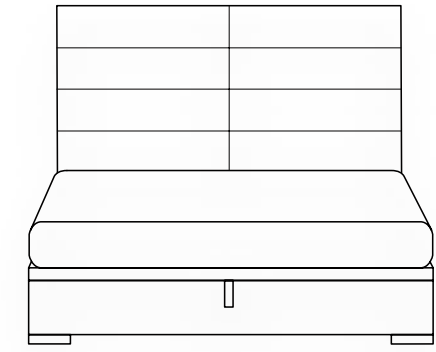

CORONA
(p. 86)

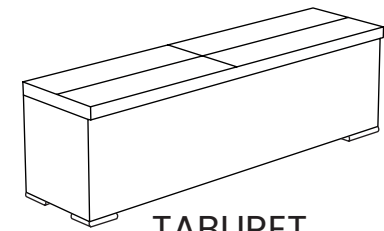

TABURET
No. 4 (p. 137)

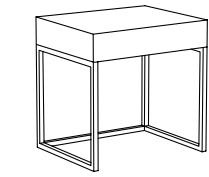

INDUSTRY
(p. 134)

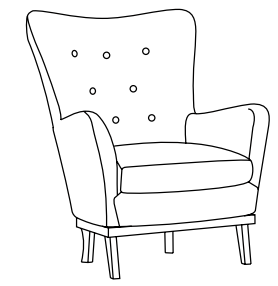

DE LUXE
(p. 128)

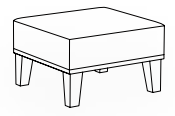

CASTELO
(p. 130)



FRANCESCA LUX SET

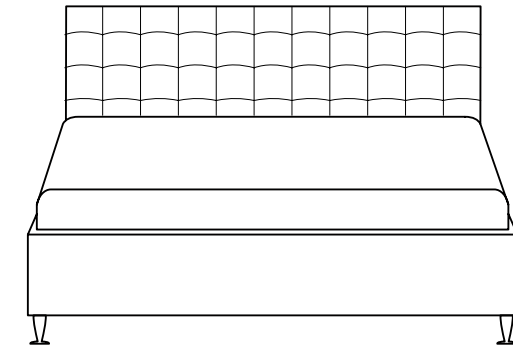

FRANCESCA LUX
(p. 75)

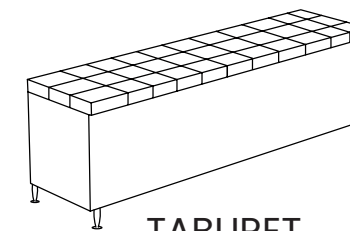

TABURET
No. 12 (p. 137)

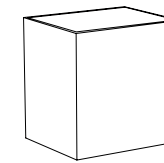

CUBE
(p. 135)

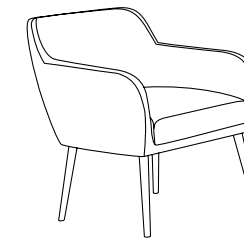

MODERN
(p. 129)



CROSS
(p. 130)



SOUL SET

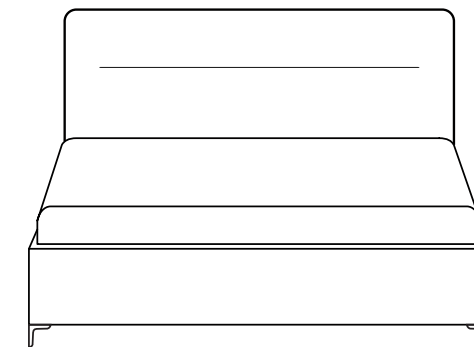

SOUL
(p. 47)

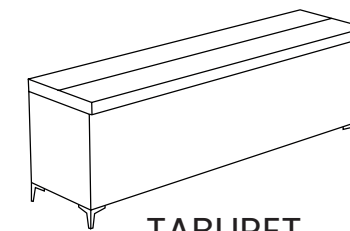

TABURET
No. 1; 3 (p. 137)

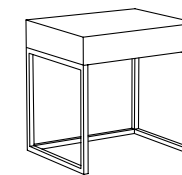

INDUSTRY
(p. 134)

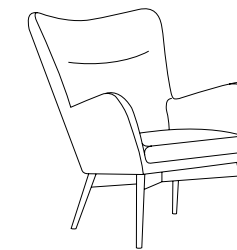

**BREEZE
MIRACH**
(p. 127)



CROSS
(p. 130)

NEW

MONZANO

	L	b ^L	b ^W	b ^H	b ^D	h ^W	h ^H	m ^L	m ^W (cm)
DESING BED	234	210	180	33	10	185	104	200	160

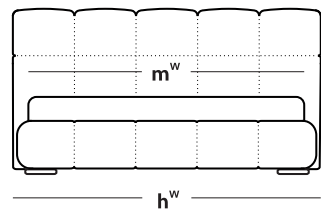
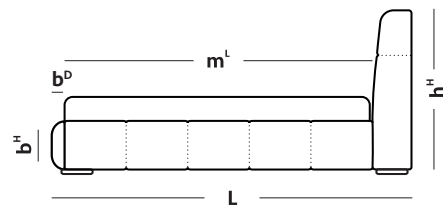
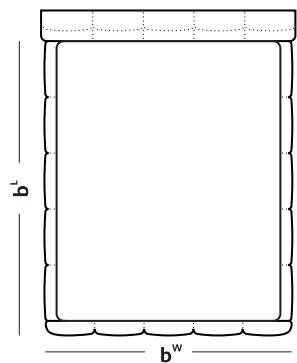

NEW

LINORA

	L	b ^L	b ^W	b ^H	h ^W	h ^H	m ^L	m ^W (cm)
DESING BED	212	205	190	30	190	110	200	180

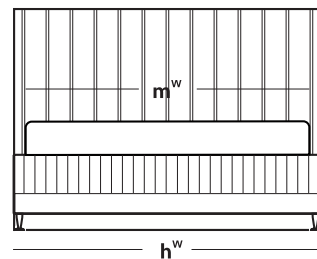
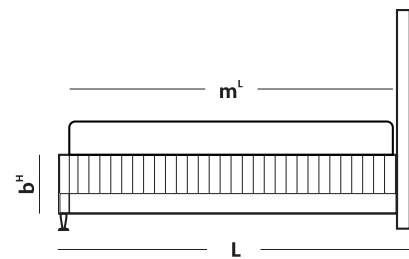
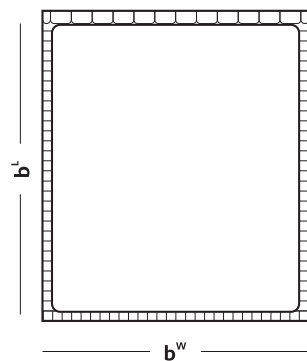

OPEN AR



ENZO

NEW

	L	b ^l	b ^w	b ^h	h ^w	h ^h	m ^l	m ^w (cm)
DESING BED	223	205	190	30	206	113	200	180

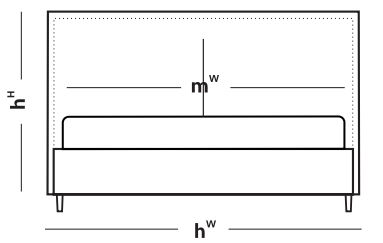
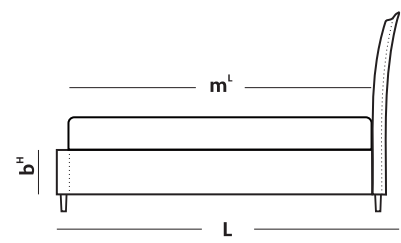
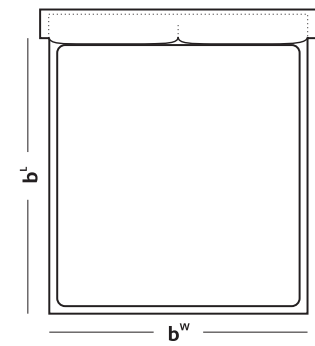

OPEN AR



SANDRO

NEW

	L	b ^l	b ^w	b ^h	h ^w	h ^h	m ^l	m ^w (cm)
DESING BED	223	205	190	30	200	110	200	180

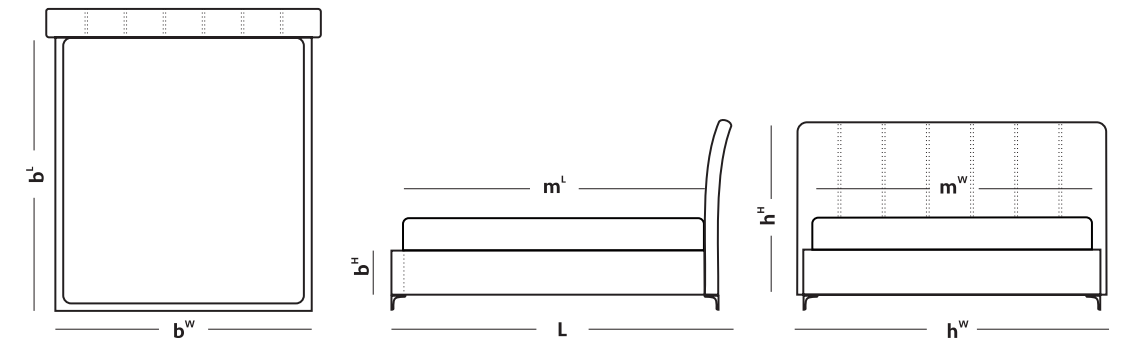



CHESS



	L	b ^l	b ^w	b ^h	h ^w	h ^h	m ^l	m ^w (cm)
DESING BED	211	205	190	30	270	130	200	180

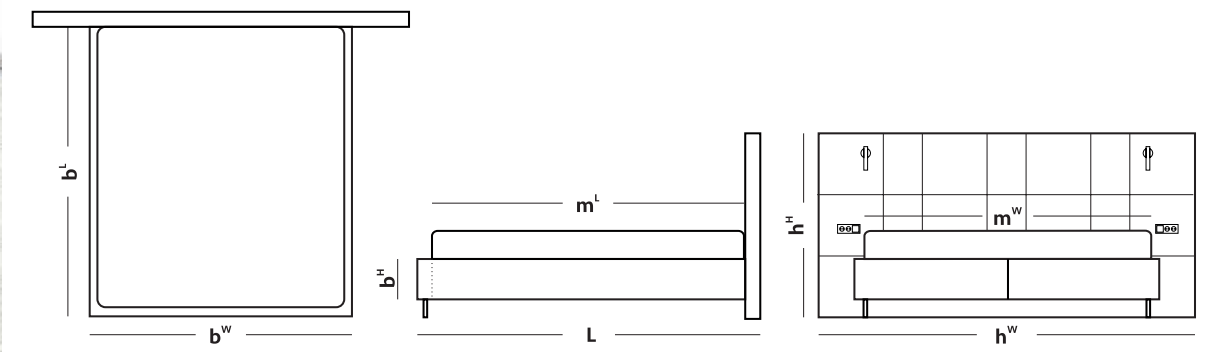



ZINA

NEW

	L	b ^l	b ^w	b ^h	h ^w	h ^h	m ^l	m ^w (cm)
DESING BED	204	200	180	10	316	139	200	180

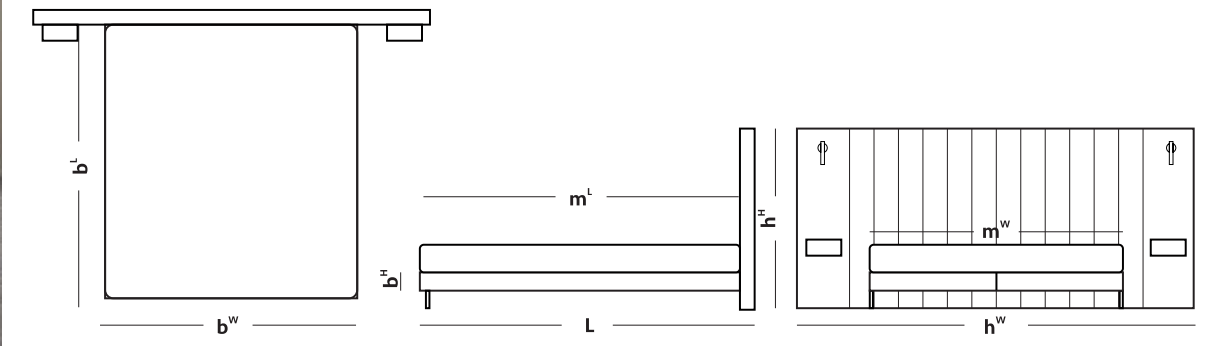



DUNA

NEW

	L	b ^L	b ^W	b ^H	h ^W	h ^H	m ^L	m ^W (cm)
DESING BED	211	205	190	30	190	111	200	180

Taburet
(p. 137)

No. 10

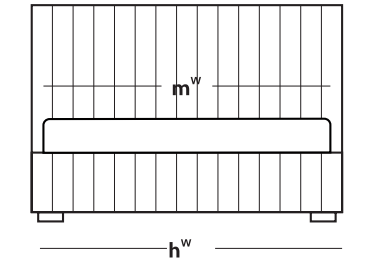
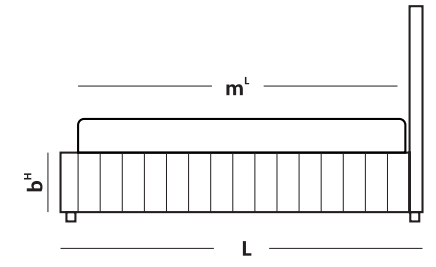
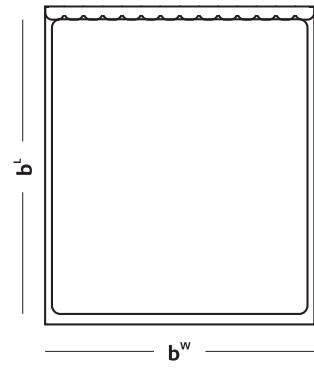
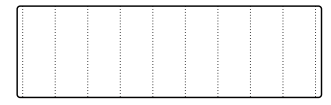



CRISTAL

	L	b ^l	b ^w	b ^h	h ^w	h ^h	m ^l	m ^w (cm)
Maxi Elektro 32	208	200	180	32	180	160	200	180

Taburet
(p. 137)

No. 5

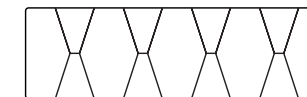

No. 1

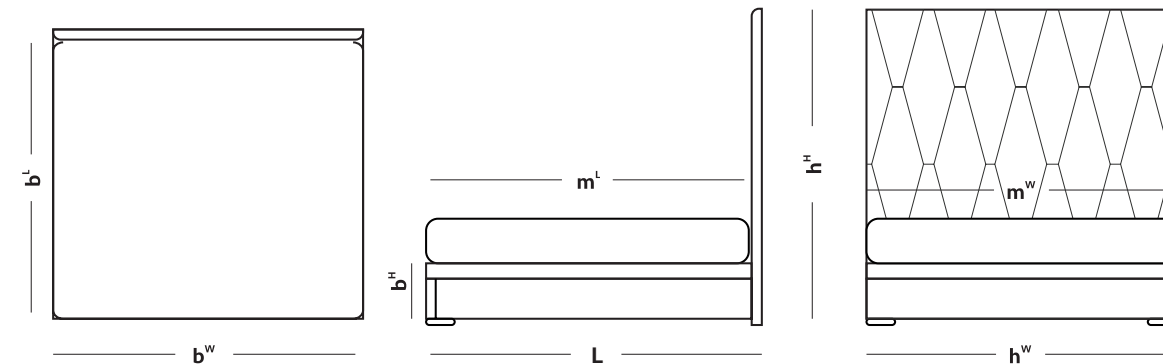



LA SPEZIA

	L	b ^L	b ^W	b ^H	h ^{W1}	h ^{W2}	h ^H	m ^L	m ^W (cm)
DESING BED	213	203	186	35	236	230	130	200	180

Taburet
(p. 137)

No. 1

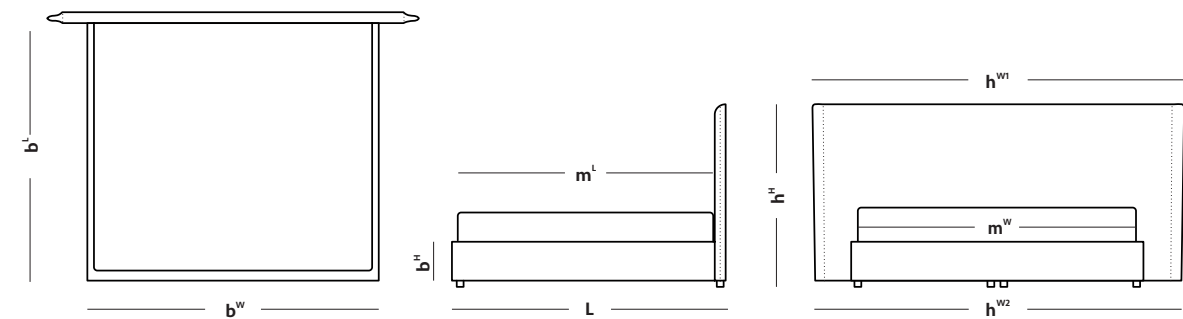

OPEN AR



Width 74.0"

Height 51.0"

17 gal
19 hwy

Front 265/35 ZR 20
Rear 325/30 ZR 21



DAMIANI

	L	b ^L	b ^W	b ^H	h ^W	h ^H	m ^L	m ^W (cm)
BOXSPRING 22	207	200	180	22	272	122	200	180

Taburet
(p. 136)

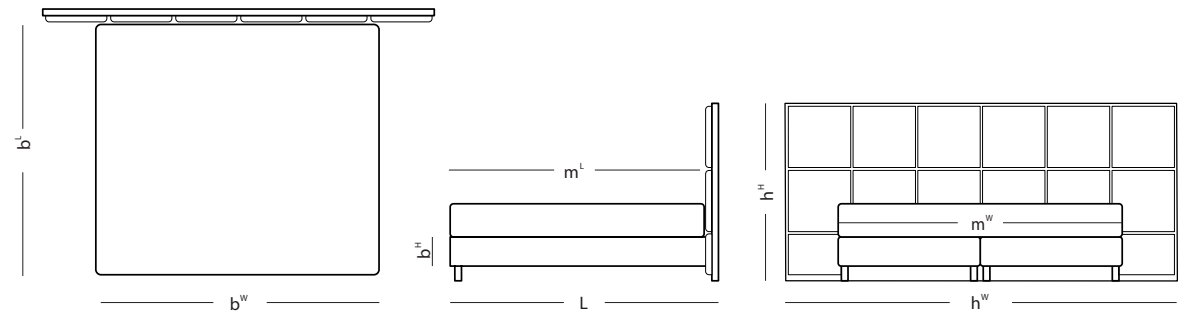
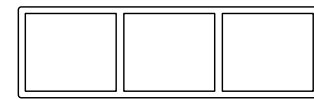



SOUL

	L	b ^L	b ^W	b ^H	b ^D	h ^W	h ^H	m ^L	m ^W (cm)
DESING BED	216	205	190	35	5	196	120	200	180
TYPE CORIUM	211	200	180	35	5	186	120	200	180

Taburet
(p. 137)

No. 1

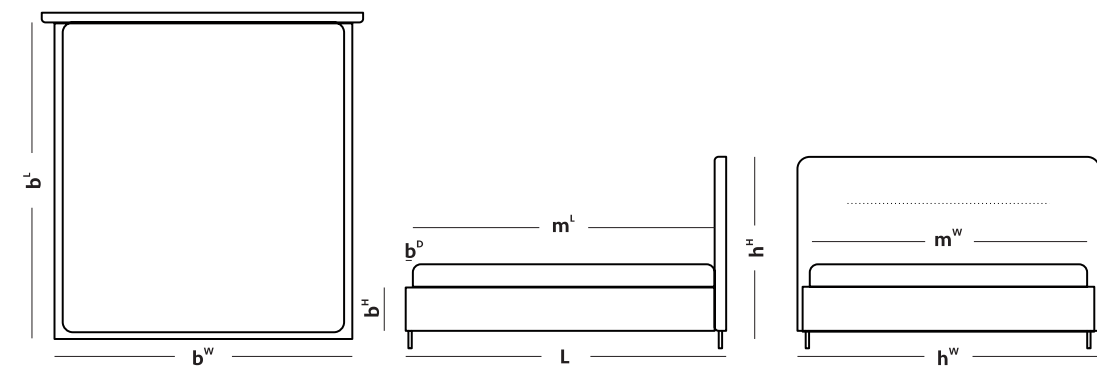



CORIUM

	L	b ^L	b ^W	b ^H	h ^W	h ^H	m ^L	m ^W (cm)
DESING BED	209	200	180	30	180	150	200	180
CORIUM	209	200	160	30	160	150	200	160

Taburet
(p. 137)

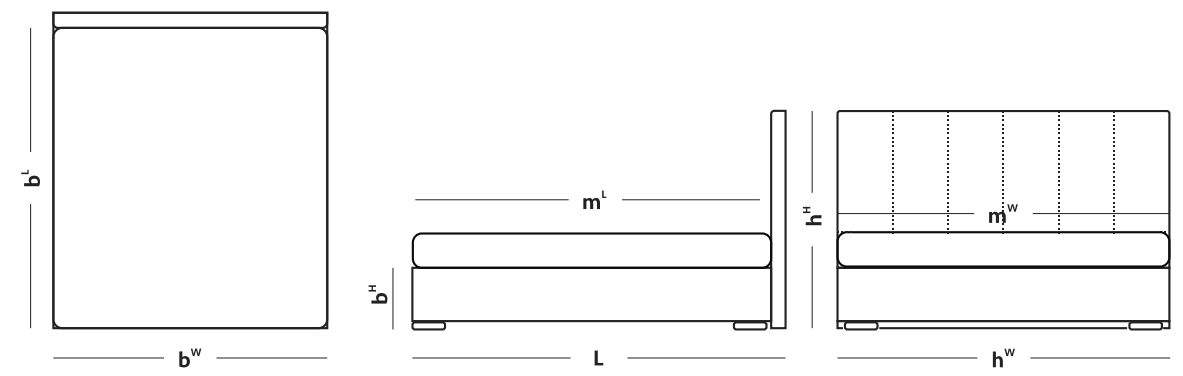
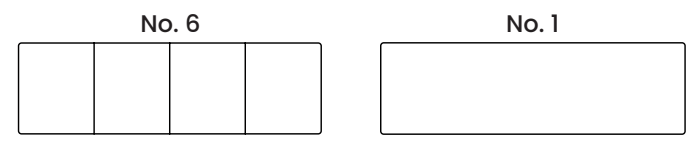



FORREST

	L	b ^l	b ^w	b ^h	h ^w	h ^h	m ^l	m ^w (cm)
BOXSPRING 32	208	200	180	32	180	160	200	180
	208	200	160	32	160	160	200	160

Taburet
(p. 137)

No. 1



No. 18

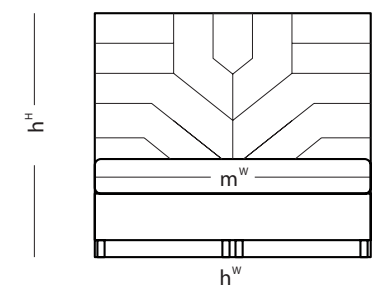
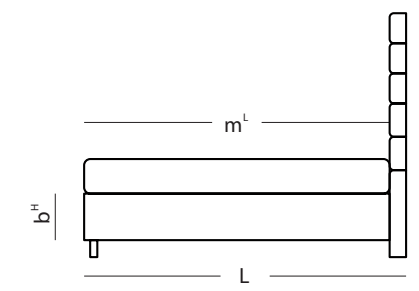
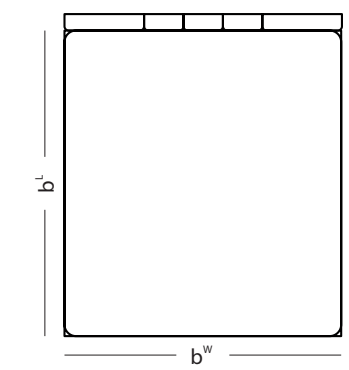
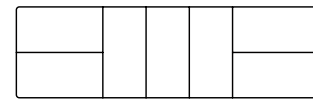



CHESTERFIELD

	L	b ^L	b ^W	b ^H	h ^W	h ^H	m ^L	m ^W (cm)
BOXSPRING 22	213	200	180	22	180	143	200	180
	213	200	160	22	160	143	200	160

Taburet
(p. 137)

No. 1



No.17

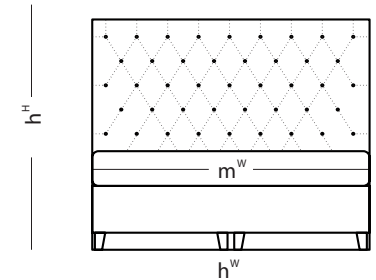
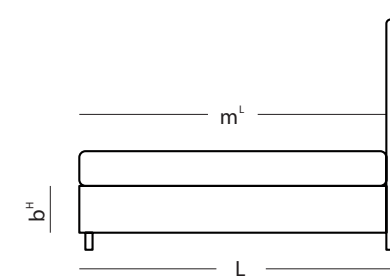
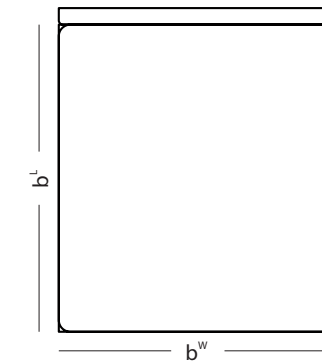
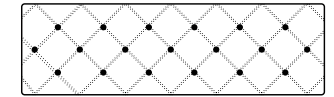



RHOMBUS

	L	b ^L	b ^W	b ^H	h ^W	h ^H	m ^L	m ^W (cm)
BOXSPRING 32	208	200	180	32	180	160	200	180
	208	200	160	32	160	160	200	160

Taburet
(p. 137)

No. 11

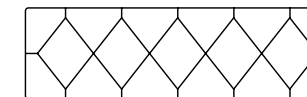

No. 1

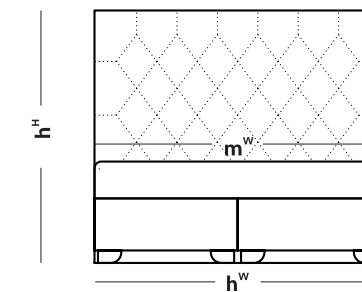
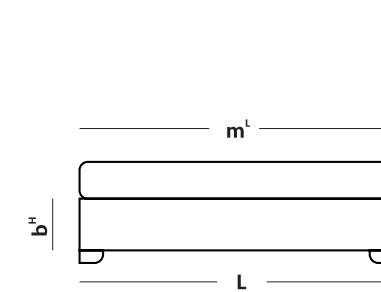
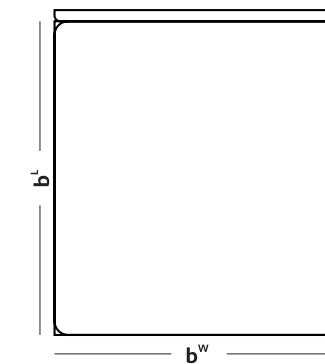



WILD

	L	b ^L	b ^W	b ^H	h ^W	h ^H	m ^L	m ^W (cm)
BOXSPRING 32	208	200	180	32	180	160	200	180
	208	200	160	32	160	160	200	160

Taburet
(p. 137)

No. 16



No. 1

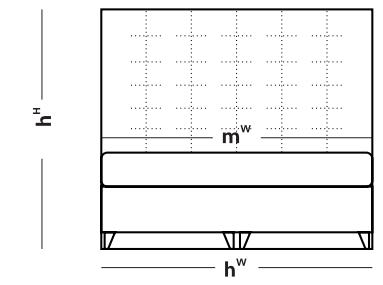
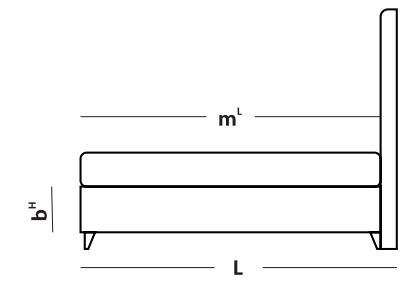
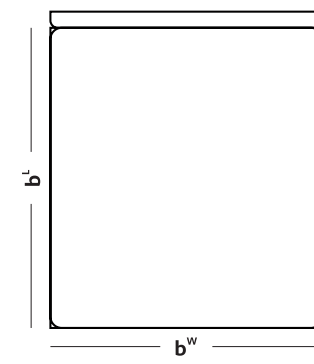



KINGSTONE

	L	b ^L	b ^W	b ^H	b ^D	h ^W	h ^H	m ^L	m ^W (cm)
DESIGN BED	218	205	190	35	5	190	120	200	180
	218	205	170	35	5	170	120	200	160

Taburet
(p. 137)

No. 2

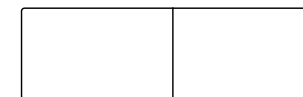

No. 1

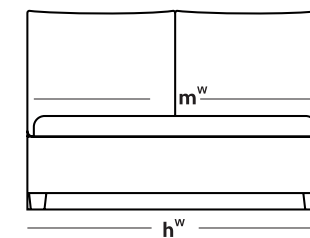
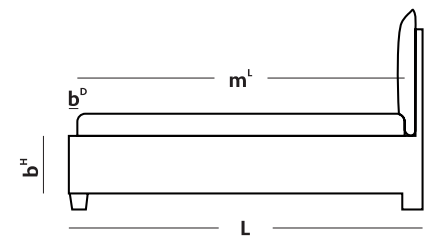
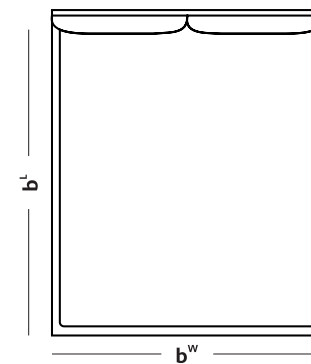



HONEY

	L	b ^L	b ^W	b ^H	b ^D	h ^W	h ^H	m ^L	m ^W (cm)
DESIGN BED	213	205	190	35	5	190	160	200	180
	213	205	170	35	5	170	160	200	160

Taburet
(p. 137)

No. 8

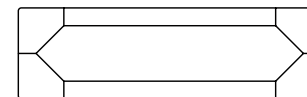

No. 1

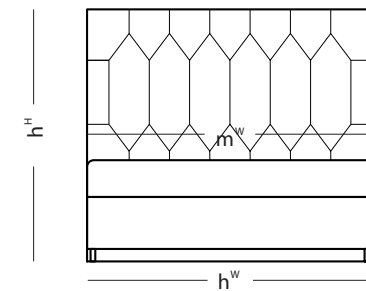
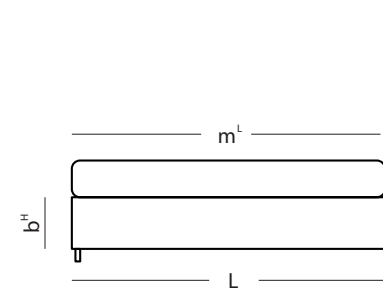
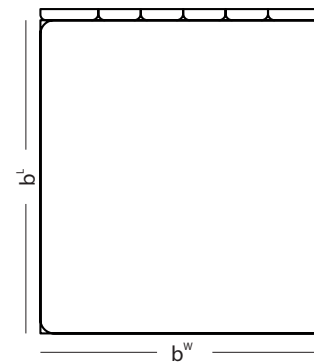

MELVA

	L	b ^l	b ^w	b ^h	h ^w	h ^h	m ^l	m ^w (cm)
BOXSPRING 32	208	200	180	32	186	160	200	180
	208	200	160	32	166	160	200	160

Taburet
(p. 137)

No. 13

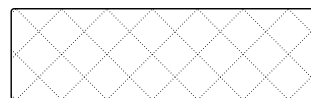

No. 1

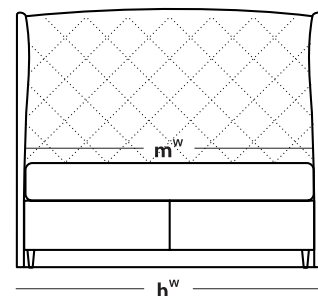
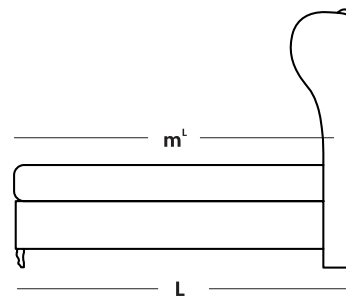
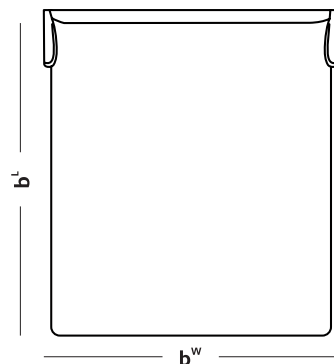

OPEN AR

SPECTRA

	L	b ^l	b ^w	b ^h	h ^w	h ^h	m ^l	m ^w (cm)
MAXI	208	200	180	32	180	130	200	180
	208	200	160	32	160	130	200	160

Taburet
(p. 137)

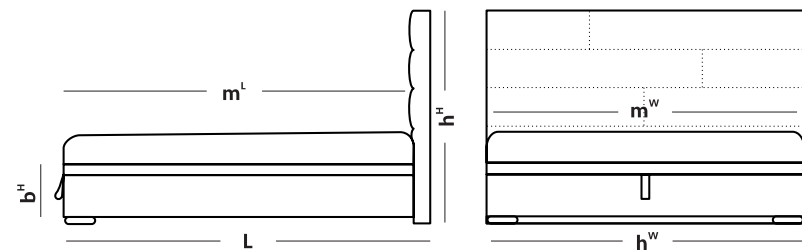
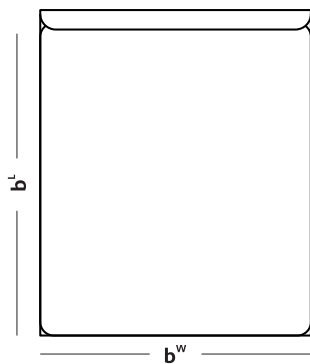
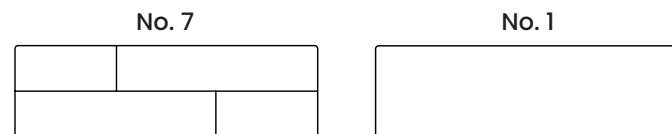

OPEN AR

HORIZONTAL

	L	b ^L	b ^W	b ^H	h ^{W1}	h ^{W2}	h ^H	m ^L	m ^W (cm)
MAXI	210	200	180	32	180	240	145	200	180
	210	200	160	32	160	220	145	200	160

Taburet
(p. 137)

No. 3

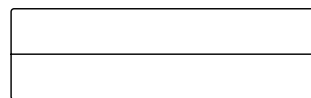

No. 1

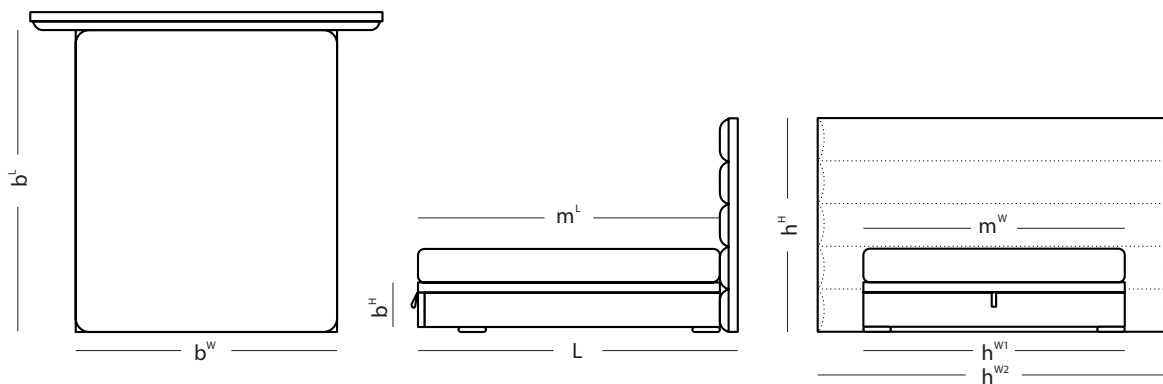

OPEN AR

NAVY

	L	b ^L	b ^W	b ^H	b ^D	h ^W	h ^H	m ^L	m ^W (cm)
DESIGN BED	213	205	190	30	5	190	123	200	180
	213	205	170	30	5	170	123	200	160

Taburet
(p. 137)

No. 1

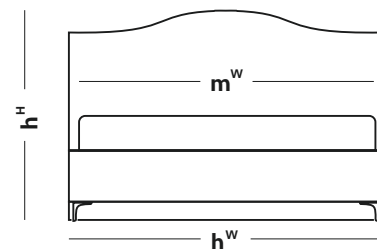
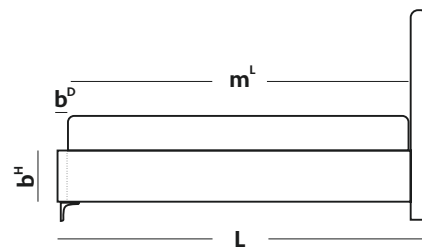
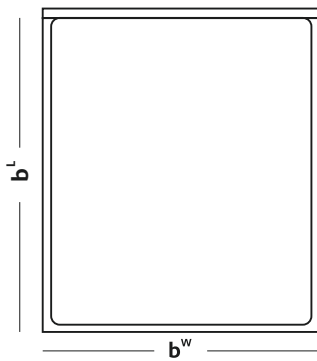

OPEN AR

ENIF

	L	b ^L	b ^W	b ^H	b ^D	h ^W	h ^H	m ^L	m ^W (cm)
DESIGN BED	213	205	190	35	5	196	123	200	180
	213	205	170	35	5	176	123	200	160

Taburet
(p. 137)

No. 1

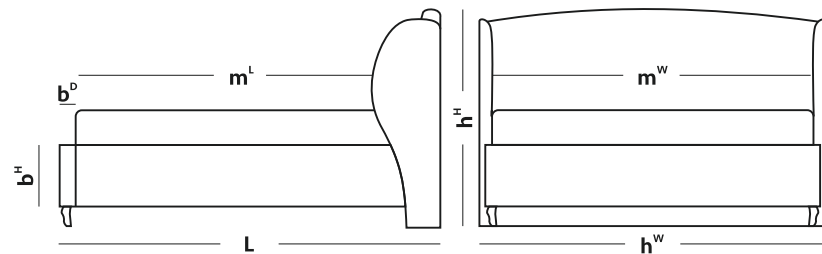
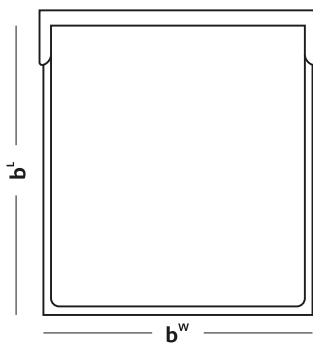

OPEN AR

GEMINI

	L	b ^L	b ^W	b ^H	b ^D	h ^W	h ^H	m ^L	m ^W (cm)
DESIGN BED	213	205	190	30	5	190	150	200	180
	213	205	170	30	5	170	150	200	160

Taburet
(p. 137)

No. 6

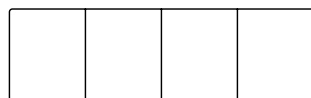

No. 1

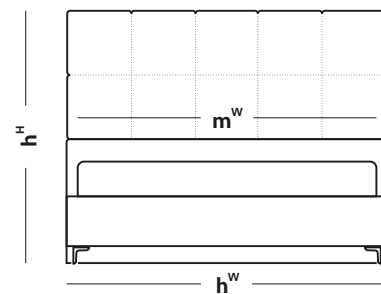
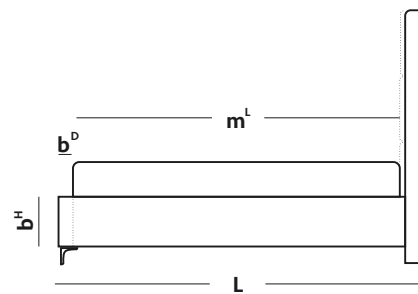
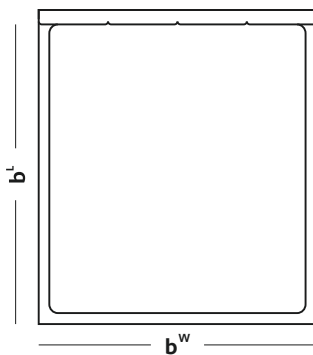

OPEN AR



FRANCESCA LUX

	L1 L2	b ^L	b ^W	b ^H	b ^D	h ^W	h ^H	m ^L	m ^W (cm)
DESIGN BED	231 216	205	190	30	5	190	103	200	180
	231 216	205	170	30	5	170	103	200	160

Taburet
(p. 137)

No. 12

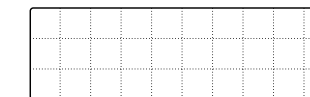

No. 1

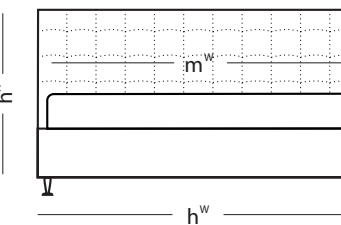
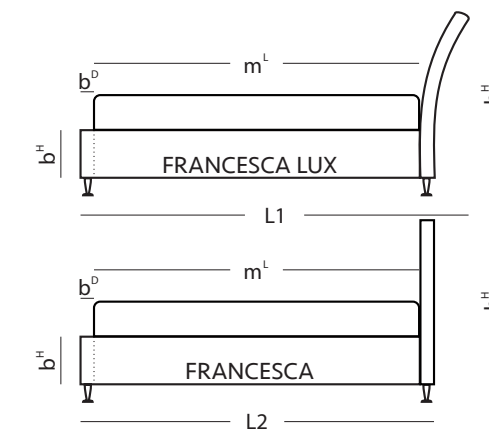
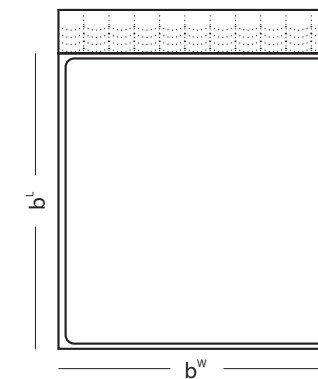



CLAUDIA LUX

	L1 L2	b ^L	b ^W	b ^H	b ^D	h ^W	h ^H	m ^L	m ^W (cm)
DESIGN BED	234 219	208	196	30	8	196	103	200	180
	234 219	208	176	30	8	176	103	200	160

Taburet
(p. 137)

No. 16

No. 1

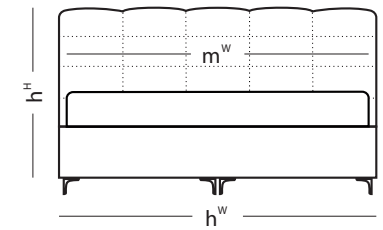
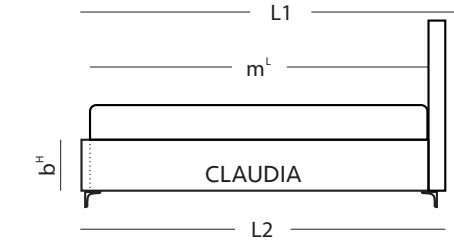
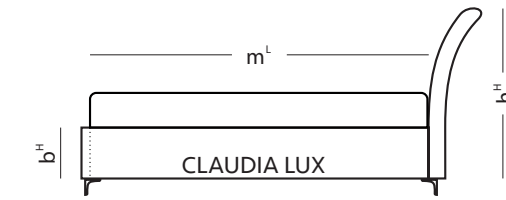
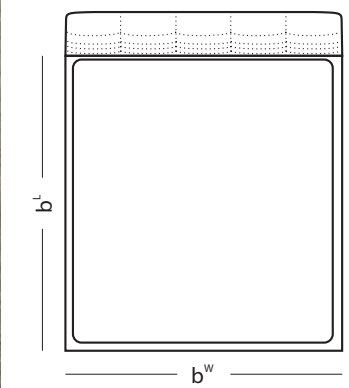
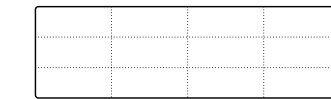

ALESIA

	L	b ^L	b ^W	b ^H	b ^D	h ^W	h ^H	m ^L	m ^W (cm)
DESIGN BED	217	205	190	30	5	190	103	200	180
	217	205	170	30	5	170	103	200	160

Taburet
(p. 137)

No. 13



No. 1

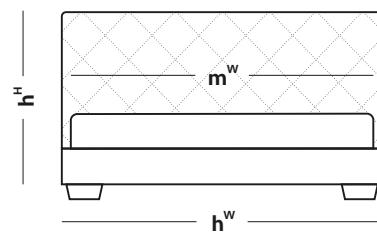
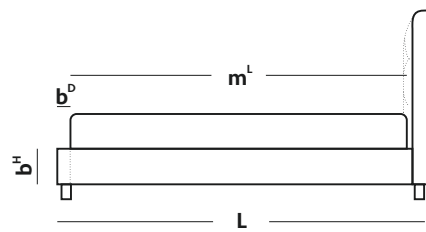
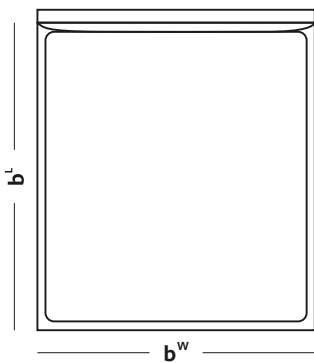

OPEN AR



VEGA

	L	b ^L	b ^W	b ^H	b ^D	h ^W	h ^H	m ^L	m ^W (cm)
DESIGN BED	213	205	190	30	5	190	130	200	180
	213	205	170	30	5	170	130	200	160

Taburet
(p. 137)

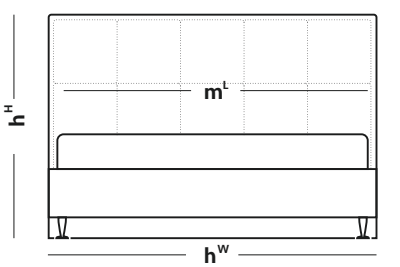
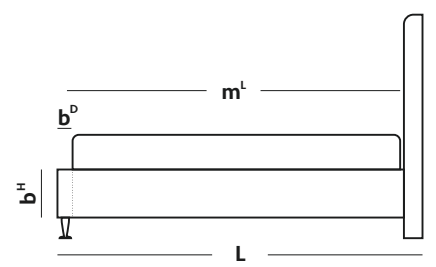
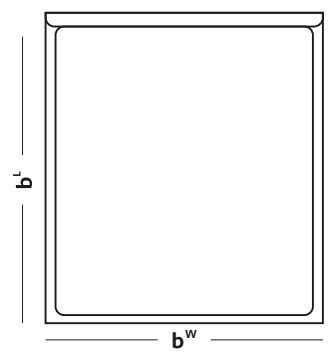
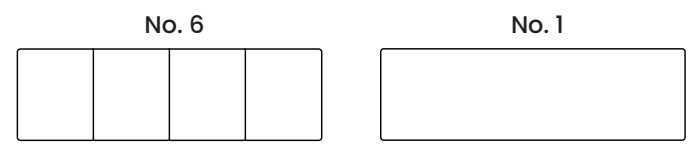



BELLATRIX

	L	b ^L	b ^W	b ^H	b ^D	h ^W	h ^H	m ^L	m ^W (cm)
DESIGN BED	213	205	190	35	5	190	120	200	180
	213	205	170	35	5	170	120	200	160

Taburet
(p. 137)

No. 10

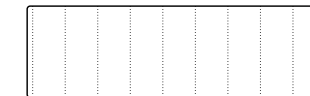

No. 1

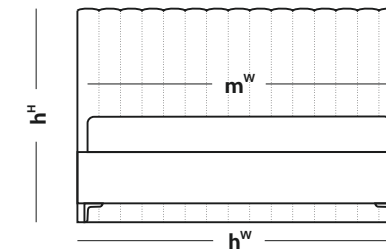
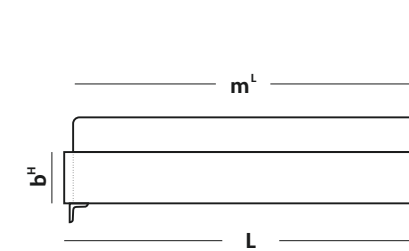
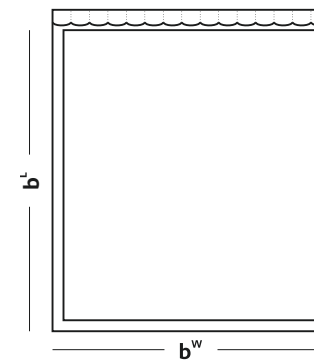

ATLAS

	L	b ^l	b ^w	b ^h	h ^w	h ^h	m ^l	m ^w (cm)
BOXSPRING 22	225	200	180	22	180	100	200	180
	225	200	160	22	160	100	200	160

Taburet
(p. 137)

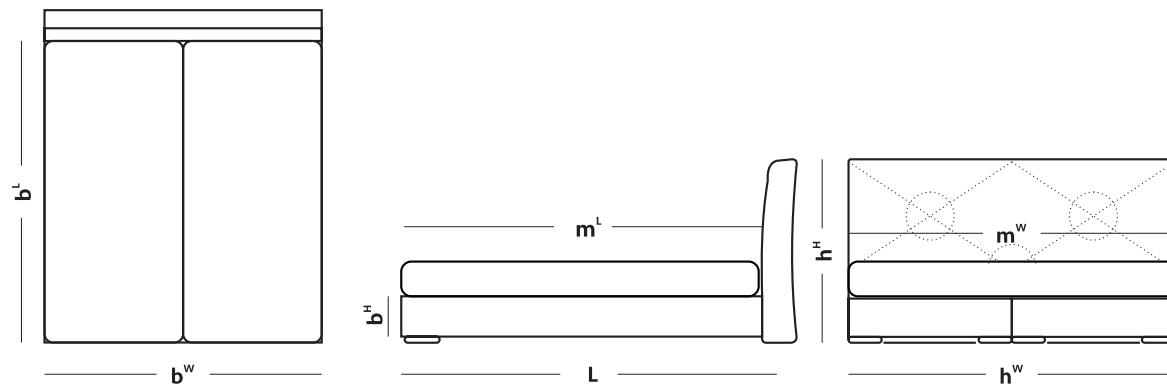
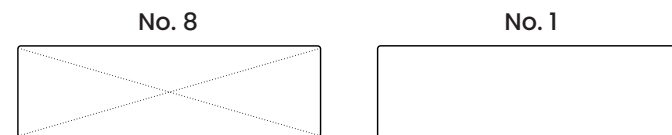

OPEN AR

CORONA

	L	b ^l	b ^w	b ^h	h ^w	h ^h	m ^l	m ^w (cm)
MAXI	208	200	180	32	180	120	200	180
	208	200	160	32	160	120	200	160

Taburet
(p. 137)

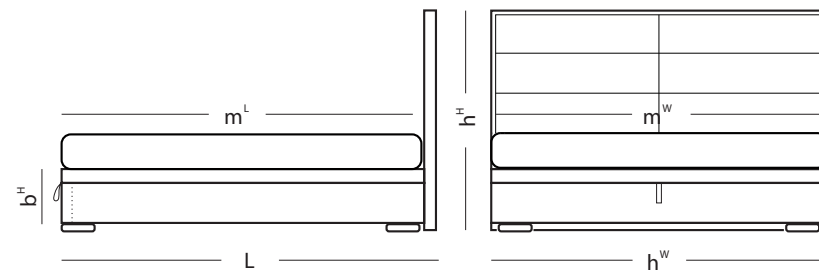
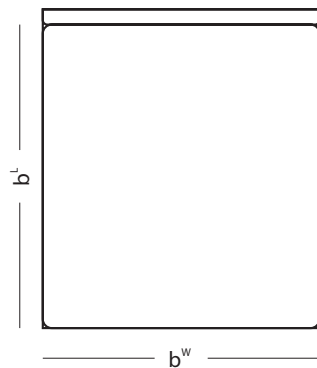
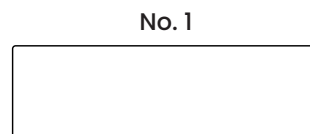
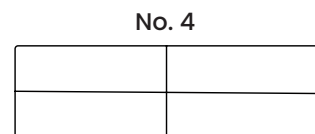

OPEN AR

MIRACH

	L	b ^l	b ^w	b ^h	h ^w	h ^h	m ^l	m ^w (cm)
BOXSPRING 22	208	200	180	22	190	130	200	180
	208	200	160	22	170	130	200	160

Taburet
(p. 137)

No. 5

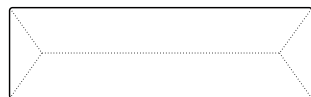

No. 1

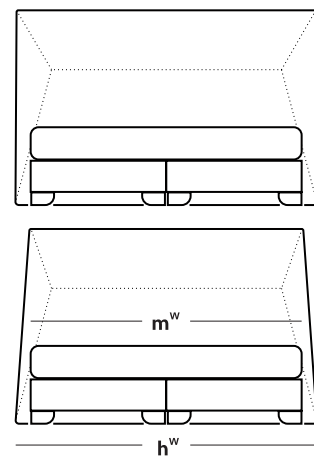
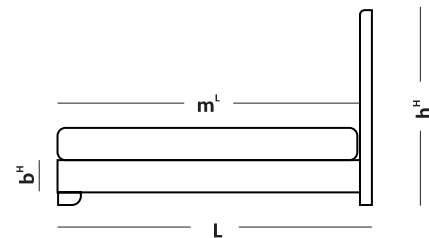
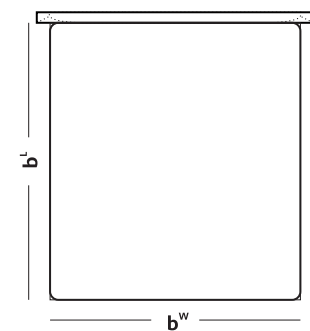

OPEN AR

PARIS

	L	b ^L	b ^W	b ^H	h ^W	h ^H	m ^L	m ^W (cm)
BOXSPRING 32	208	200	180	32	180	197	200	180
+ COVER	208	200	160	32	160	197	200	160

Taburet
(p. 137)

No. 6

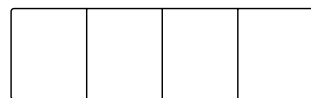

No. 1

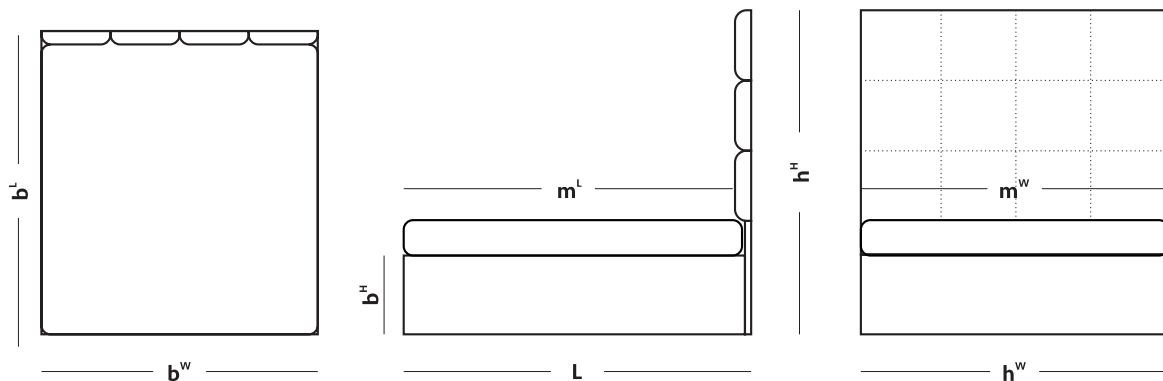

90



OPEN AR

VIENNA

	L	b ^L	b ^W	b ^H	h ^W	h ^H	m ^L	m ^W (cm)
BOXSPRING 32	208	200	180	32	190	160	200	180
	208	200	160	32	170	160	200	160

Taburet
(p. 137)

No. 15

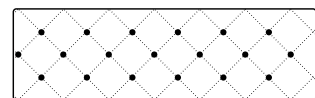

No. 1

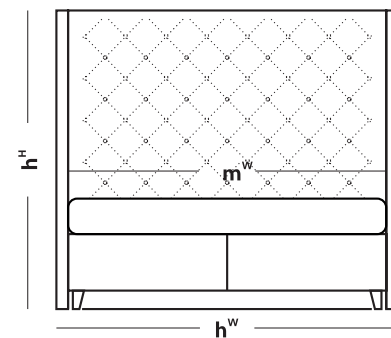
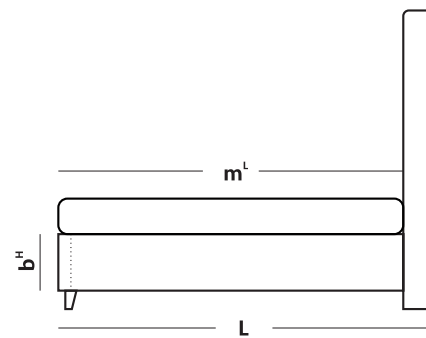
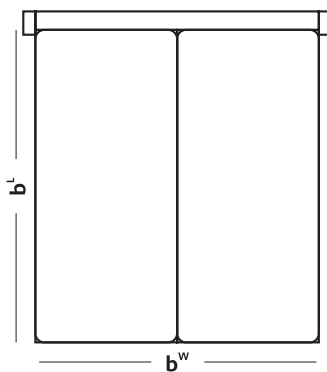

OPEN AR

NOBILIA

	L	b ^L	b ^W	b ^H	b ^D	h ^W	h ^H	m ^L	m ^W (cm)
DESIGN BED	213	205	190	30	5	190	120	200	180
	213	205	170	30	5	170	120	200	160

Taburet
(p. 137)

No. 9



No. 1

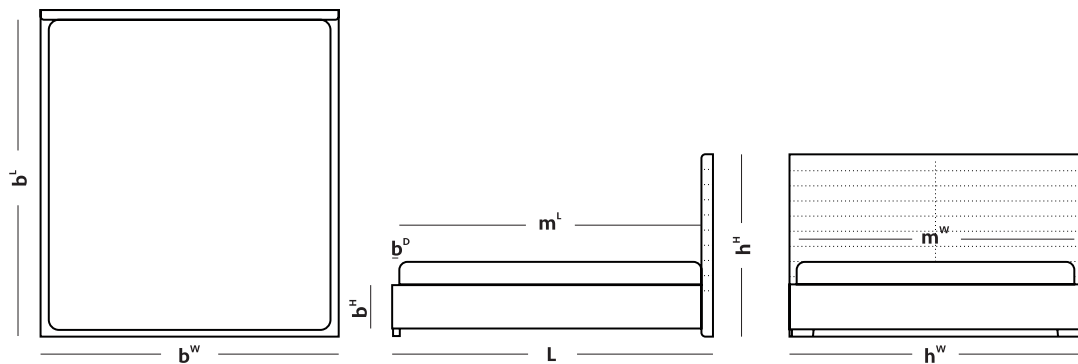



ARGENTINA

	L	b ^L	b ^W	b ^H	b ^D	h ^W	h ^H	m ^L	m ^W (cm)
DESIGN BED	213	205	190	35	5	190	120	200	180
	213	205	170	35	5	170	120	200	160

Taburet
(p. 137)

No. 1

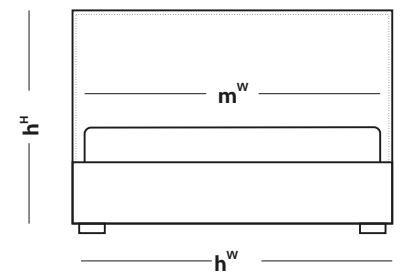
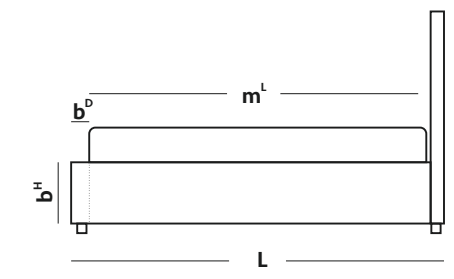
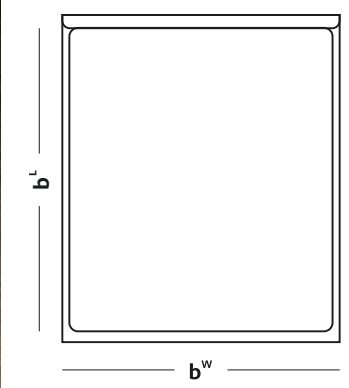



SIRIUS

	L	b ^L	b ^W	b ^H	h ^W	h ^H	m ^L	m ^W (cm)
BOXSPRING MOBIL	208	200	180	32	180	120	200	180
	208	200	160	32	160	120	200	160

Taburet
(p. 137)

No. 1

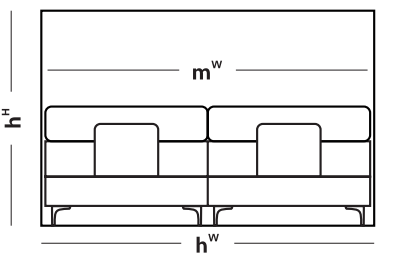
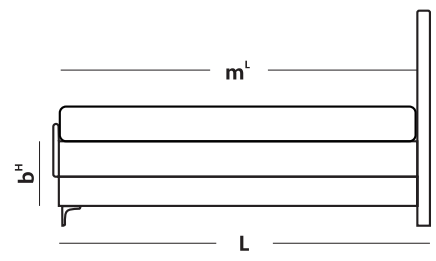
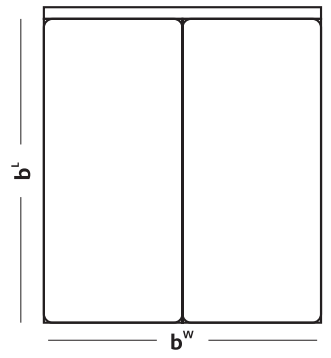
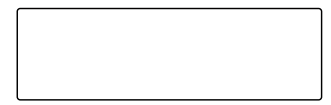



VELORUM

	L	b ^L	b ^W	b ^H	h ^W	h ^H	m ^L	m ^W (cm)
BOXSPRING 32	208	200	180	32	180	120	200	180
	208	200	160	32	160	120	200	160

Taburet
(p. 137)

No. 14

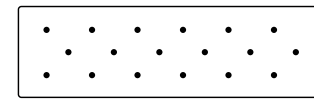

No. 1

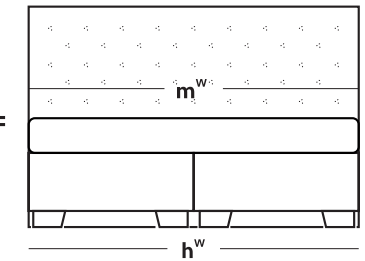
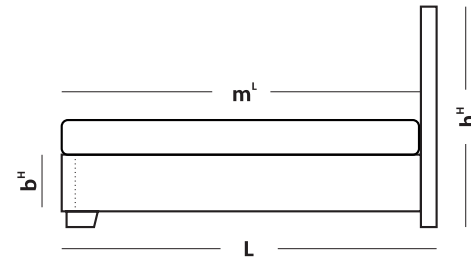
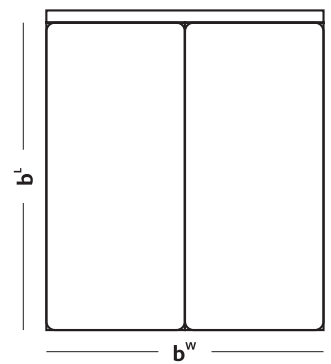



CORIUM SLIDE

NEW

	L	b ^L	b ^W	b ^H	h ^W	h ^H	m ^L	m ^W (cm)
BOXSPRING	210	200	95	46	105	120	200	95
Slide							185	90

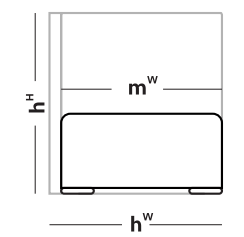
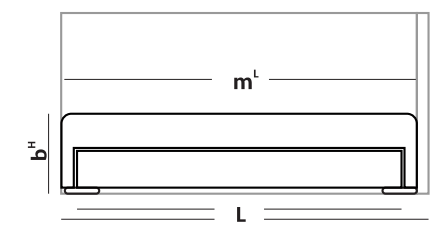
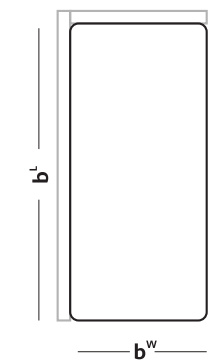



WALL

NEW

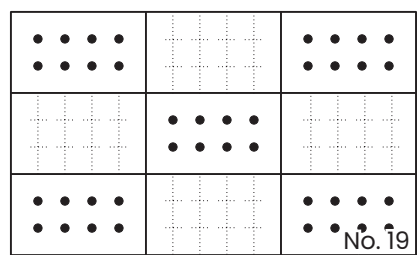
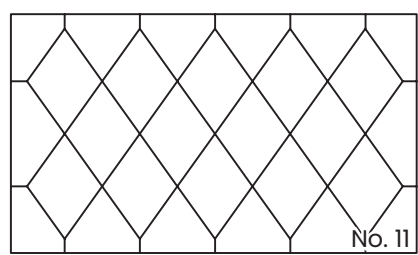
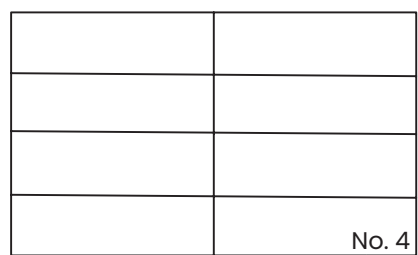
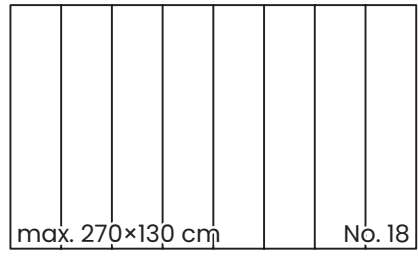
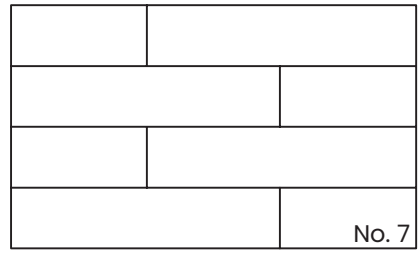
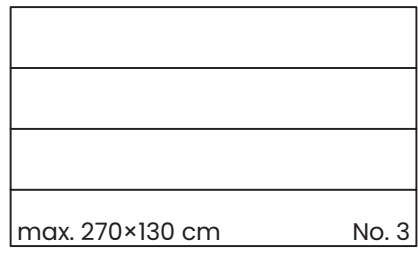
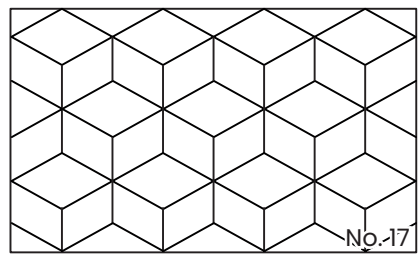
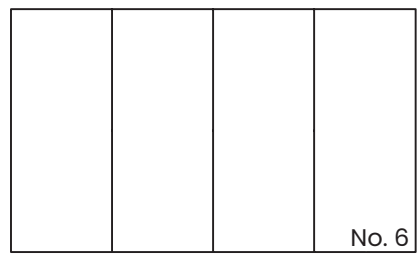
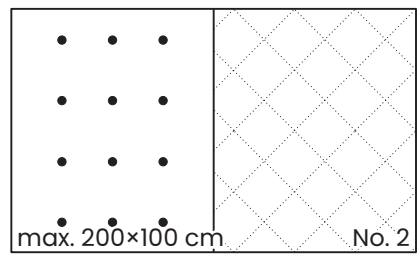



TWINS

L	b ^w	b ^H	b ^{H1}	b ^{H2}	m ^L	m ^w (cm)
224	100	197	30	154	200	90

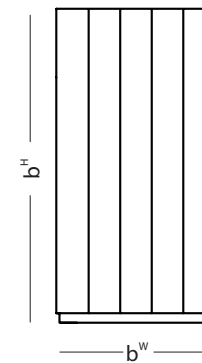
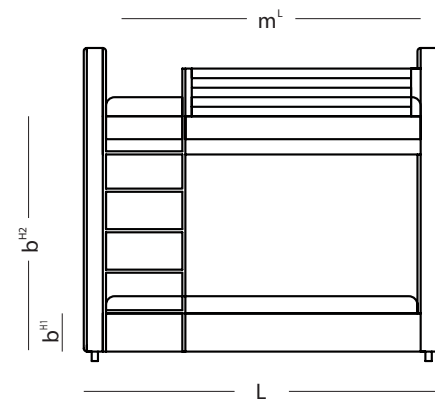
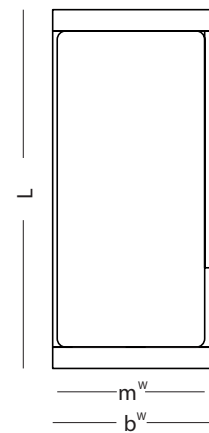

NEW



AMIRA

L	b	h	L ^r	h ^r	L ^w	h ^w (cm)
200	80/90	22 - 45	70	23	80/90	28

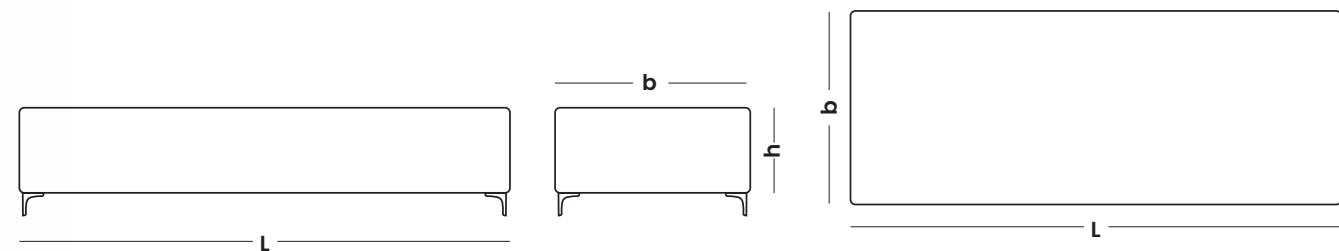
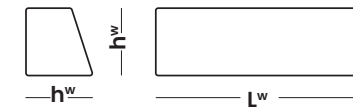
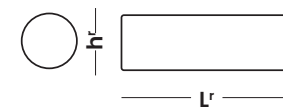

NEW



SIESTA

a	b	c	d	e	f	g	h	L (cm)
80	88	40	75	14	5	60	86	188

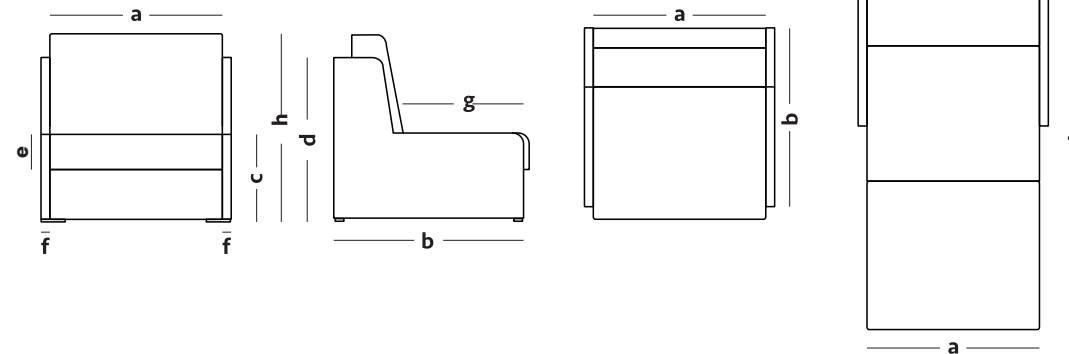

NEW



SOFABED BARI

	a	b	c	d	e	f	g	m ^l	m ^w	L (cm)
BARI DOUBLE	210	49	68	100	62	30	152	190	140	240
BARI TRIPLE	230	49	68	100	62	30	172	190	160	240

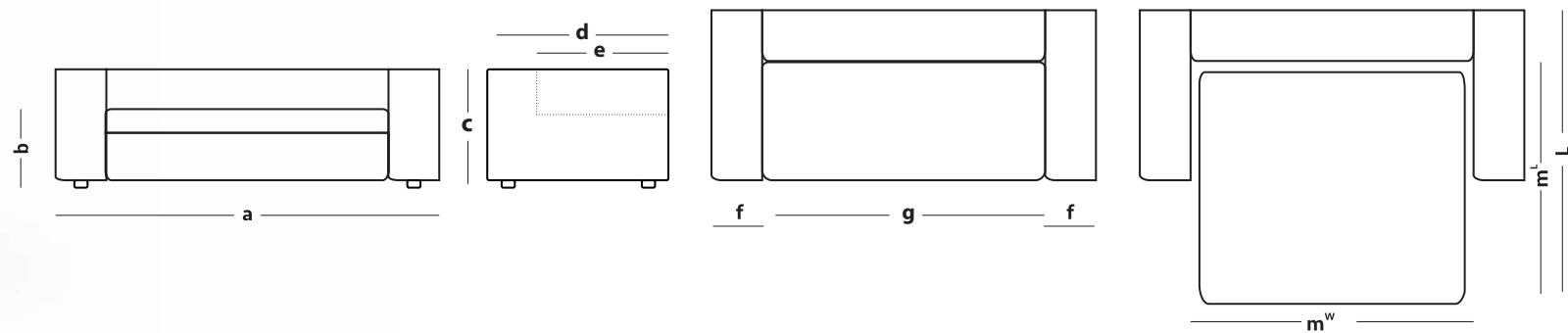

NEW



SOFABED TORVI

	a	b	c	d	e	f	g	h	m ^l	m ^w	L (cm)
SOFABED DOUBLE	163	93	55	56	183	10	60	96	190	140	215
SOFABED TRIPLE	183	93	55	56	203	10	60	96	190	160	215

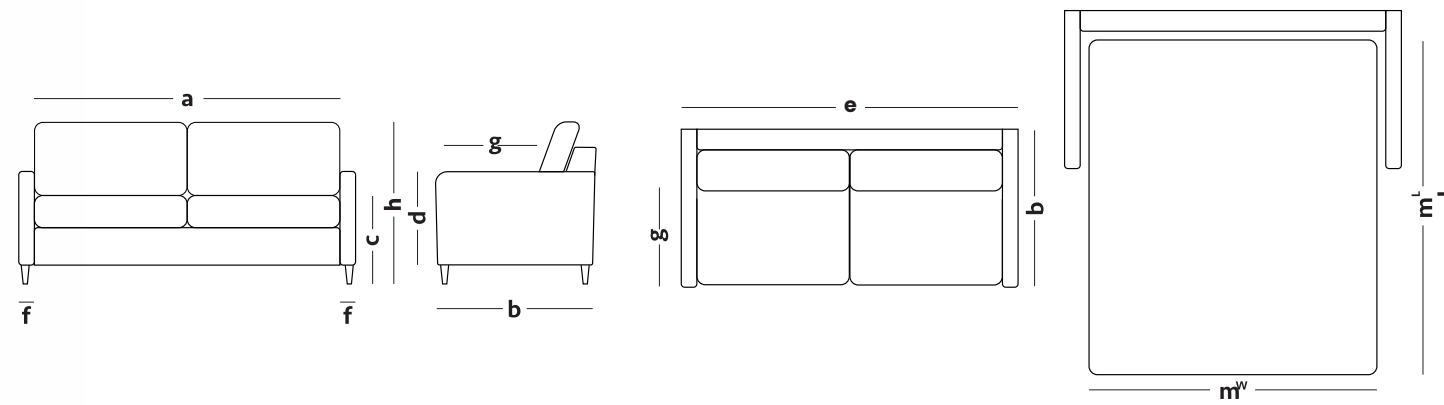



SOFABED SINGLE

a	b	c	d	f	g	h	m ^L	m ^w	L	(cm)
103	98	48	60	13 17 21	55	85	190	80	215	

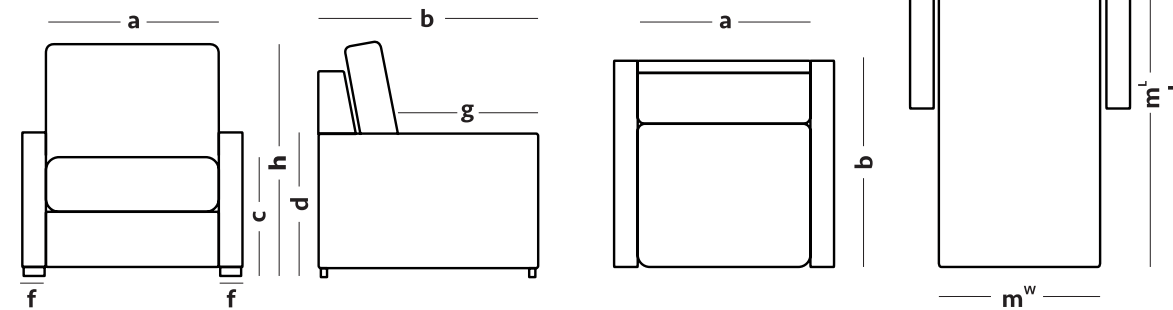



SOFABED DOUBLE

	a	b	c	d	f	g	h	m ^l	m ^w	L (cm)
SOFABED DOUBLE	163	98	48	60	13 17 21	55	85	190	140	215
SOFABED TRIPLE	183	98	48	60	13 17 21	55	85	190	160	215

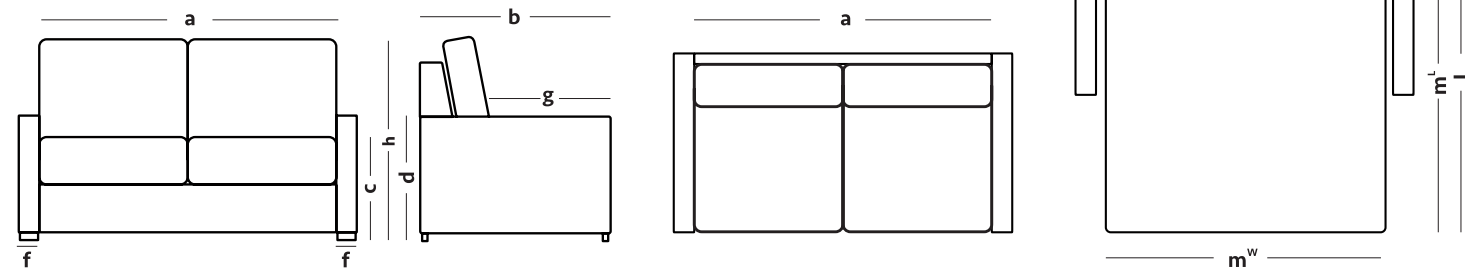

BOUDOIR MONT BLANC

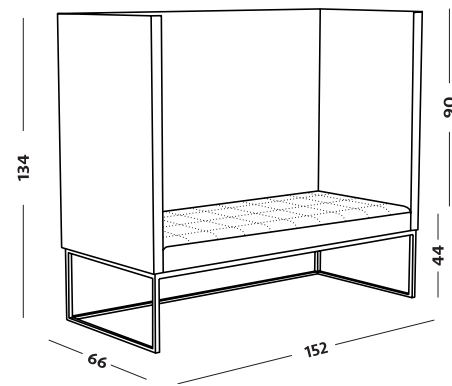

MONT BLANC

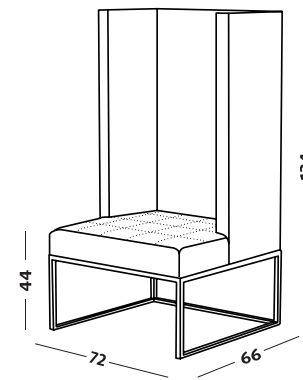



BOSS

a	b	c	d	e	f	g	h	i	(cm)
50	50	105	95	50	50	78	95	30	

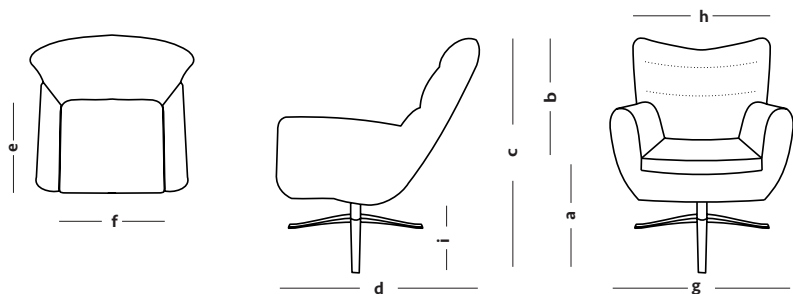

MOON

a	b	c	d	(cm)
93	90	45	63	

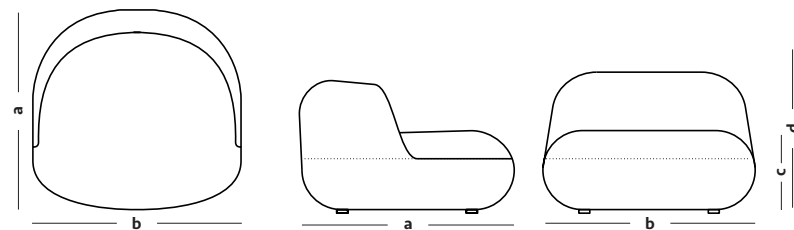

PUFF

NEW

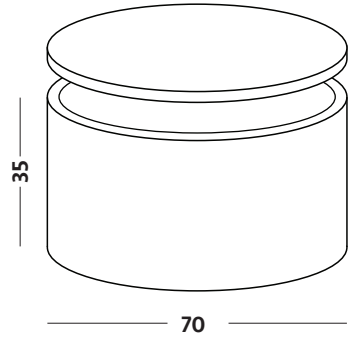

NAEL

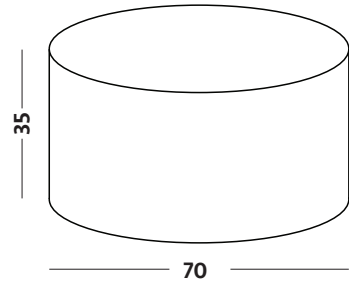

MONI

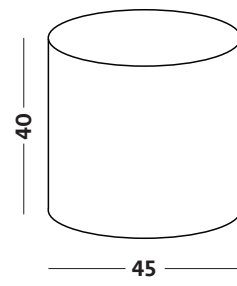

OLI

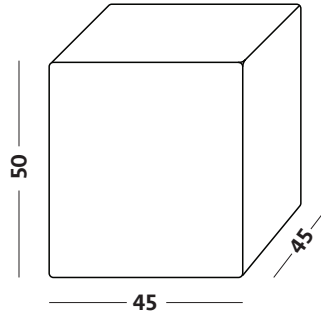

TINA

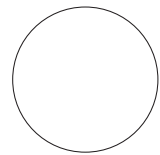

No. 1

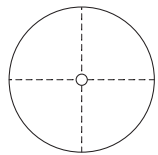

No. 2

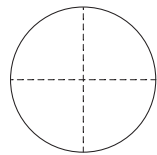

No. 3

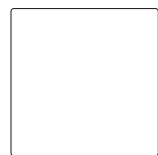

No. 1

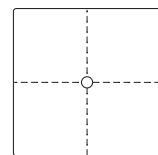

No. 2

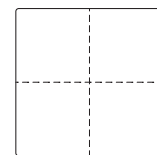

No. 3





BOUDOIR BREEZE

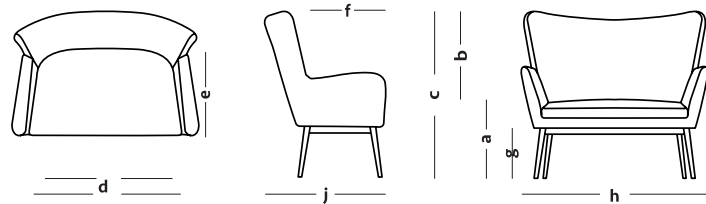

	a	b	c	d	e	f	g	h	j	(cm)
CROSS	45	53	98	116 100	56	54	31	140	84	

BREEZE

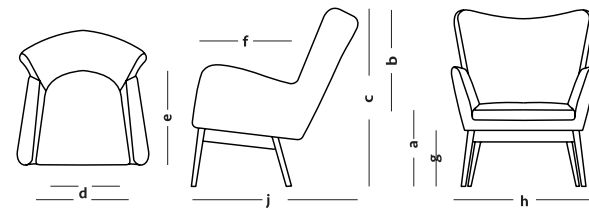

	a	b	c	d	e	f	g	h	j	(cm)
CUT	45	63	94	56 42	56	42	26 31	78	85	
CROSS	45	63	102	56 42	56	42	32	78	80	

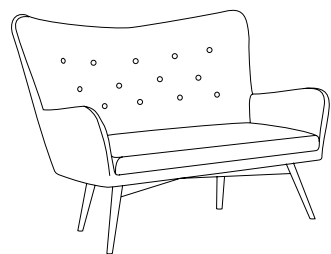

Button

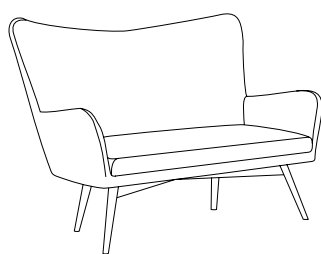

Clean

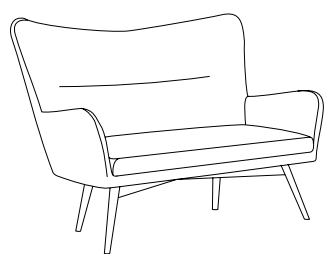

Mirach

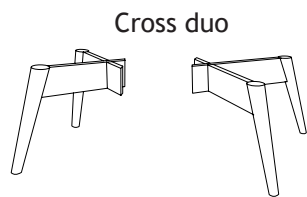

Cross duo

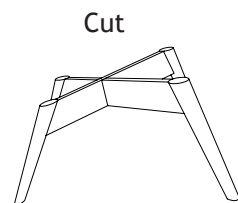

Cut

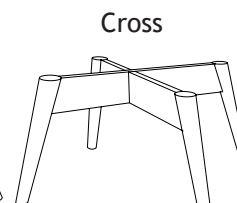

Cross

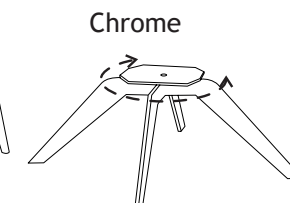

Chrome

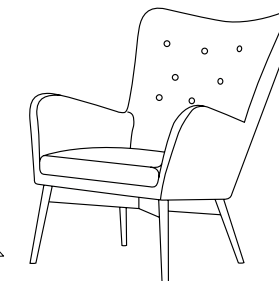

Button

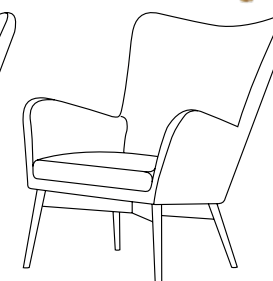

Clean

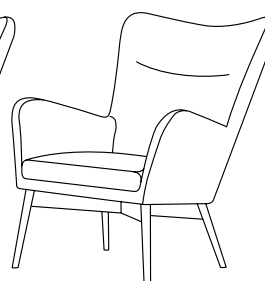

Mirach



DE LUXE

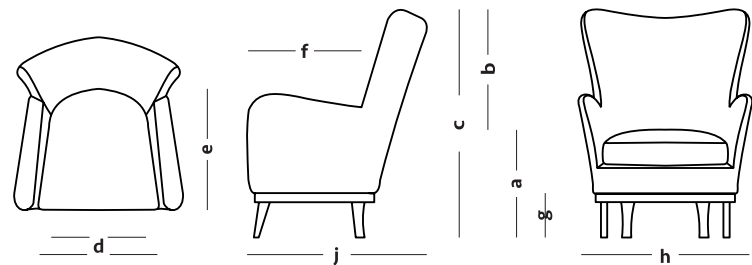

	a	b	c	d	e	f	g	h	j	(cm)
CASTEL	45	55	100	56 42	54	49	20	79	80	
LINE	46	55	101	56 42	54	49	21	79	80	

MODERN

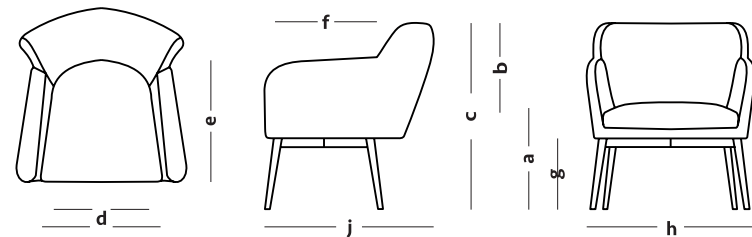

	a	b	c	d	e	f	g	h	j	(cm)
CUT	45	33	69	55 44	56	42	26 31	75	79	
CROSS	45	33	78	55 44	56	42	32	75	75	

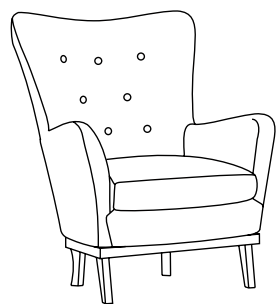

Button

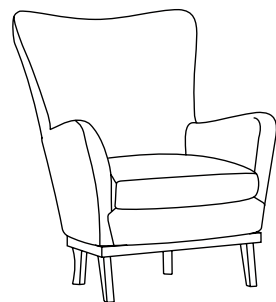

Clean

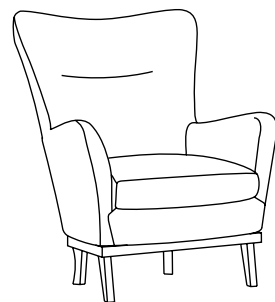

Mirach

Castelo

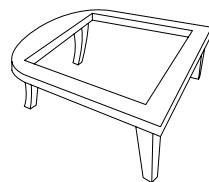

Line

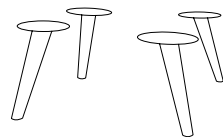

Cut

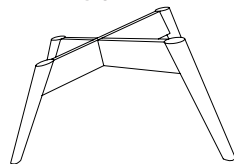

Cross

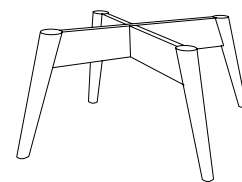

Chrome

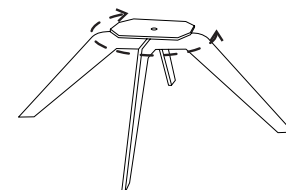

CUT

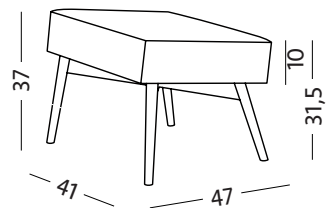

CASTELO

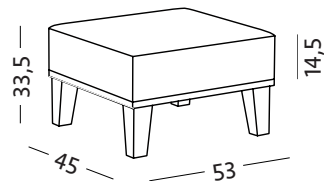

CROSS

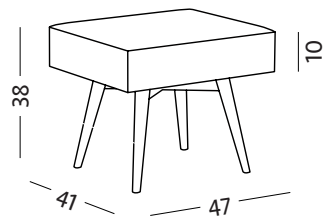

DAMIANI SWISS

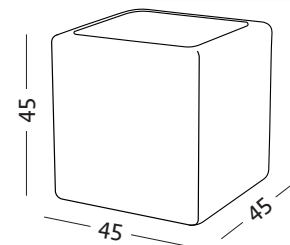

VITO DARK / LIGHT

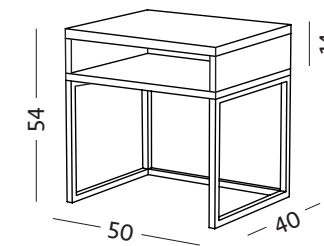

PIETRO DARK / LIGHT

NEW

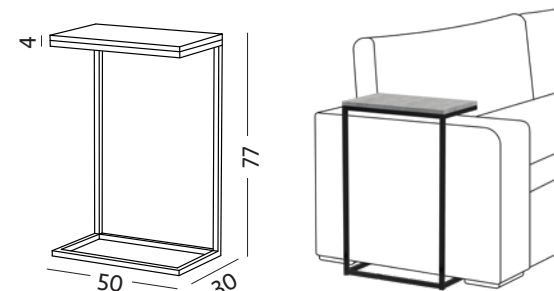

NEW

NIMO

DARK / LIGHT

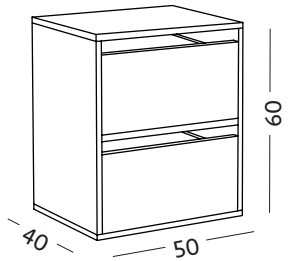

VITORIO U

DARK / LIGHT

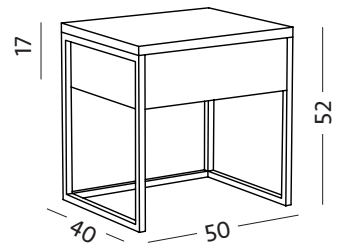

VITORIO L

DARK / LIGHT

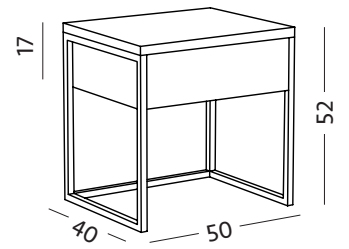

ANA

DARK / LIGHT

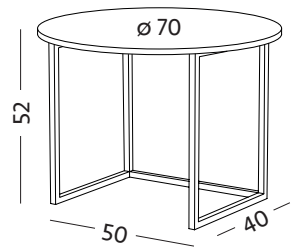

ANITA

DARK / LIGHT

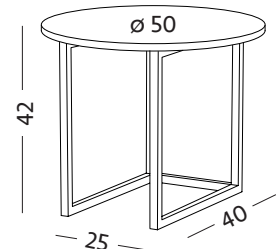

NEW



DARK

LIGHT

INDUSTRY

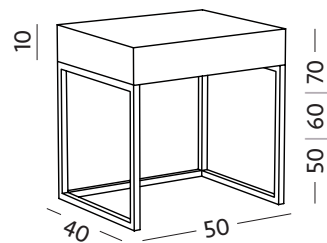

HEAVY OAK

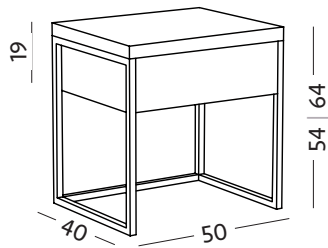

OAK

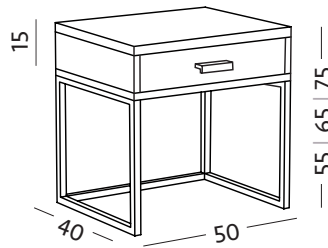

DAMIANI

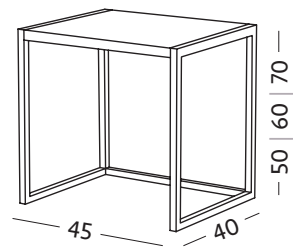

CUBE

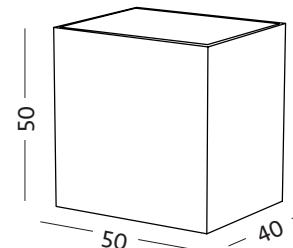

LA SPEZIA

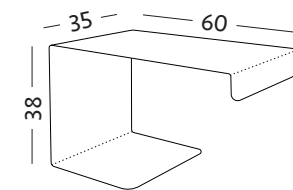

TABURET | BENCH

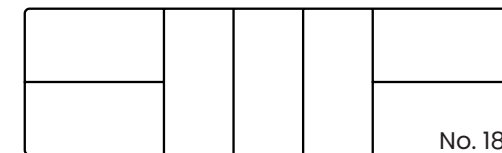
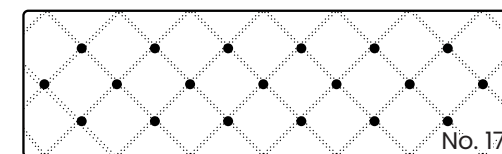
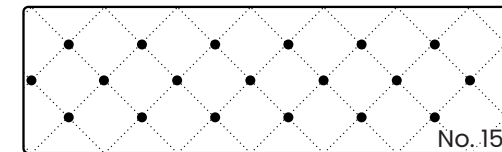
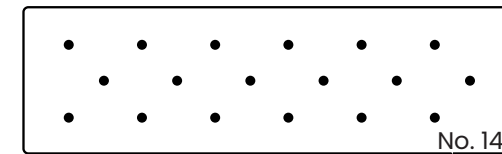
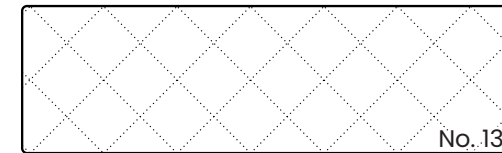
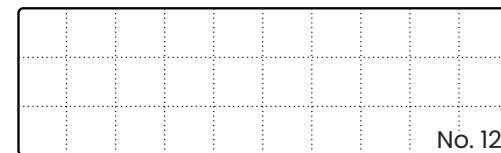
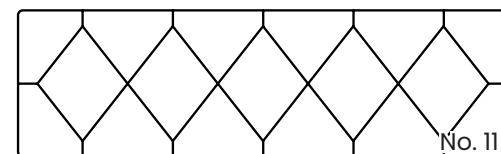
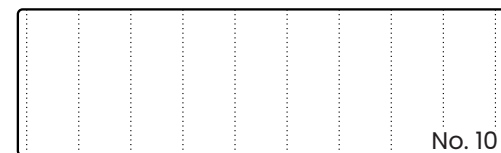
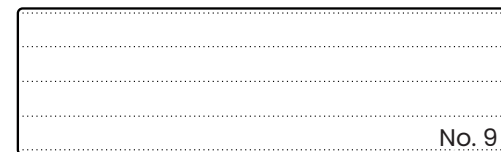
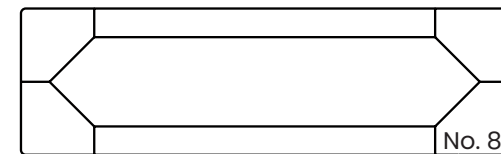
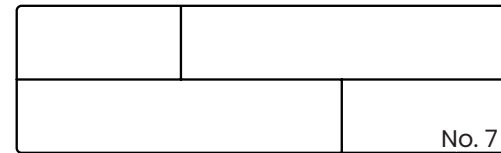
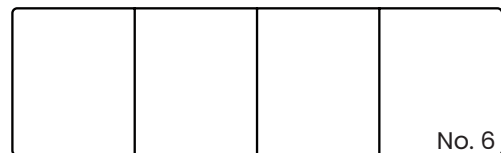
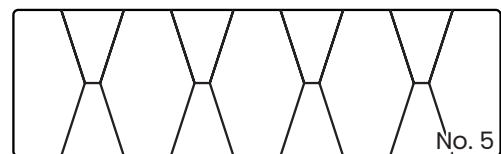
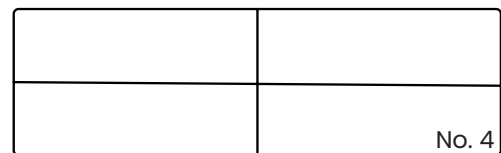
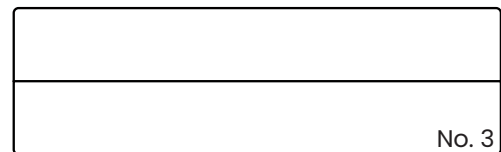
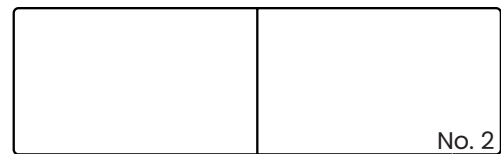
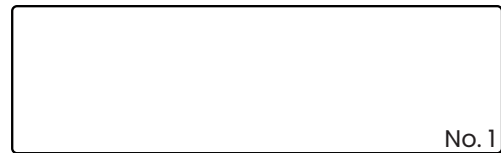
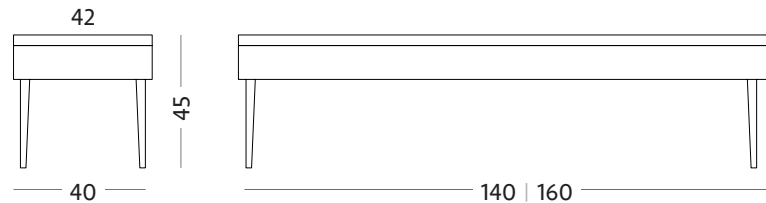
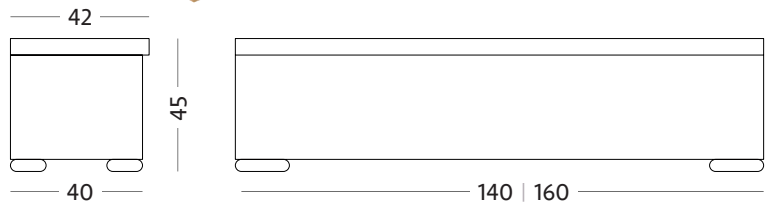

NEW



Flute

120 | 150 | 190 mm - black, bronze, chrome, gold

NEW



Line

120 | 150 | 220 mm - chrome, black, white

NEW



Light

150 mm - black

NEW



Floor angle

200×200×20 mm - chrome

NEW



Floor tube

200 mm × 32 mm - chrome



Floor

150×150×30 mm - chrome

NEW



Capri

200 mm - black | 190 mm - chrome

NEW



Dual

150 mm - black

NEW



Spider

120 | 150 mm - chrome

NEW



Fancy

130 mm - chrome



Industry

130 mm - black

NEW



Elegance

130 mm - black, white, chrome, gold



Polygon

100 mm - chrome



Metal

80 mm - chrome



Block ·

100 | 130 | 160 mm – natur, walnut, gray, wenge, black



Wood 1

88 | 100 | 130 mm – natur, gray, walnut, wenge, black



Tulip

130 mm – natur



Castello

130 mm – walnut



Cube

100 mm – cherry



Wood 2

80 mm – natur, walnut, gray, wenge, black



Wood 4

110 mm – natur, walnut, gray, wenge, black



Wood 5

110 mm – natur, walnut, gray, wenge, black

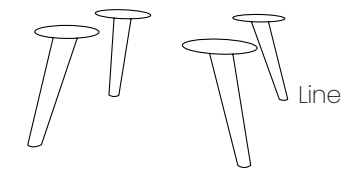

Line

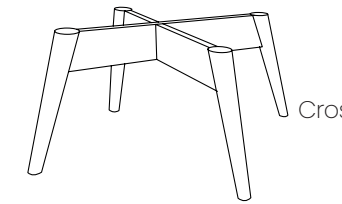

Cross

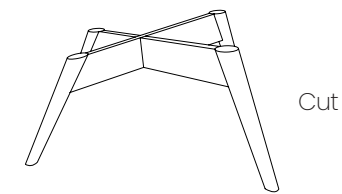

Cut

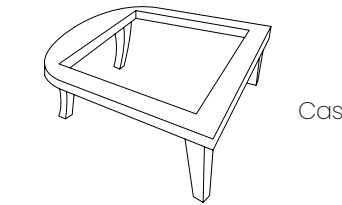

Castello

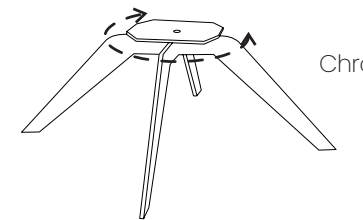

Chrome



Natur

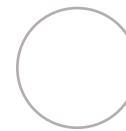

White



Walnut

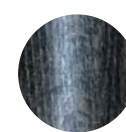

Wenge



- SK** Obsah katalógu je duševným vlastníctvom firmy MATERASSO Slovakia, s.r.o. Použití tieto materiály je možné len s uvedením ich vlastníka: © MATERASSO Slovakia, s.r.o. Nedodržanie týchto podmienok je právne **vymáhateľné ako porušenie autorských práv**. Farby použitých materiálov sú ilustračné, môžu byť odlišné od skutočnosti.
- CZ** Obsah katalogu je duševním vlastnictvím firmy MATERASSO Slovakia, s.r.o. Použití tyto materiály lze pouze s uvedením jejich vlastníka: © MATERASSO Slovakia, s.r.o. Nedodržení těchto podmínek je právně **vymáhateľné jako porušení autorských práv**. Barvy použitých materiálů jsou ilustrační, mohou být odlišné od skutečnosti.
- EN** The content of the catalogue is the intellectual property of MATERASSO Slovakia, s.r.o. It is possible to use these materials only with the indication of their owner: © MATERASSO Slovakia, s.r.o. Failure to comply with these terms and conditions is legally **enforceable as copyright infringement**. The colors of the materials used are illustrative, they may differ from the actual ones.
- PL** Zawartość katalogu jest własnością intelektualną MATERASSO Slovakia, s.r.o. Korzystanie z tych materiałów jest możliwe tylko za wskazaniem ich właściciela: © MATERASSO Slovakia, s.r.o. Nieprzestrzeganie tych warunków jest prawnie **egzekwowalne jako naruszenie praw autorskich**. Kolory użytych materiałów mają charakter poglądowy, mogą różnić się od rzeczywistych.
- HU** A katalógus tartalma a MATERASSO Slovakia, s.r.o. szellemi tulajdonát képezi. Ezeket az anyagokat csak a tulajdonos feltüntetésével lehet felhasználni: © MATERASSO Slovakia, s.r.o. E feltételek be nem tartása jogilag **érvényesíthető szerzői jogsértésként**. A felhasznált anyagok színei illusztrációs célokat szolgálnak, és eltérhetnek a valóságtól.
- DE** Der Inhalt des Katalogs ist geistiges Eigentum von MATERASSO Slovakia, s.r.o. Die Nutzung dieser Materialien ist nur mit Angabe des Eigentümers möglich: © MATERASSO Slovakia, s.r.o. Die Nichteinhaltung dieser Bestimmungen und Bedingungen kann als **Urheberrechtsverletzung rechtlich verfolgt werden**. Die Farben der verwendeten Materialien sind illustrativ, sie können von den tatsächlichen abweichen.

m
Materasso
www.materasso.cz
2026

